

New!

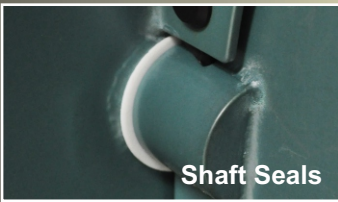

Nylon Bearings



Shaft Seals

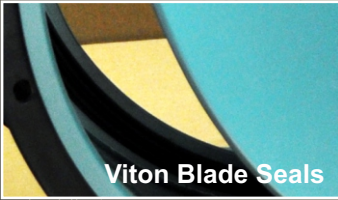

Viton Blade Seals

Cost Effective

High Value Heavy Duty PSP[®] Damper from Fab-Tech

The same all stainless steel construction,
and Fab-Tech's proprietary fluoropolymer coating,
but at a **lower cost!**

*SHOWN WITH MANUAL HANDLE ACTUATOR OPTION

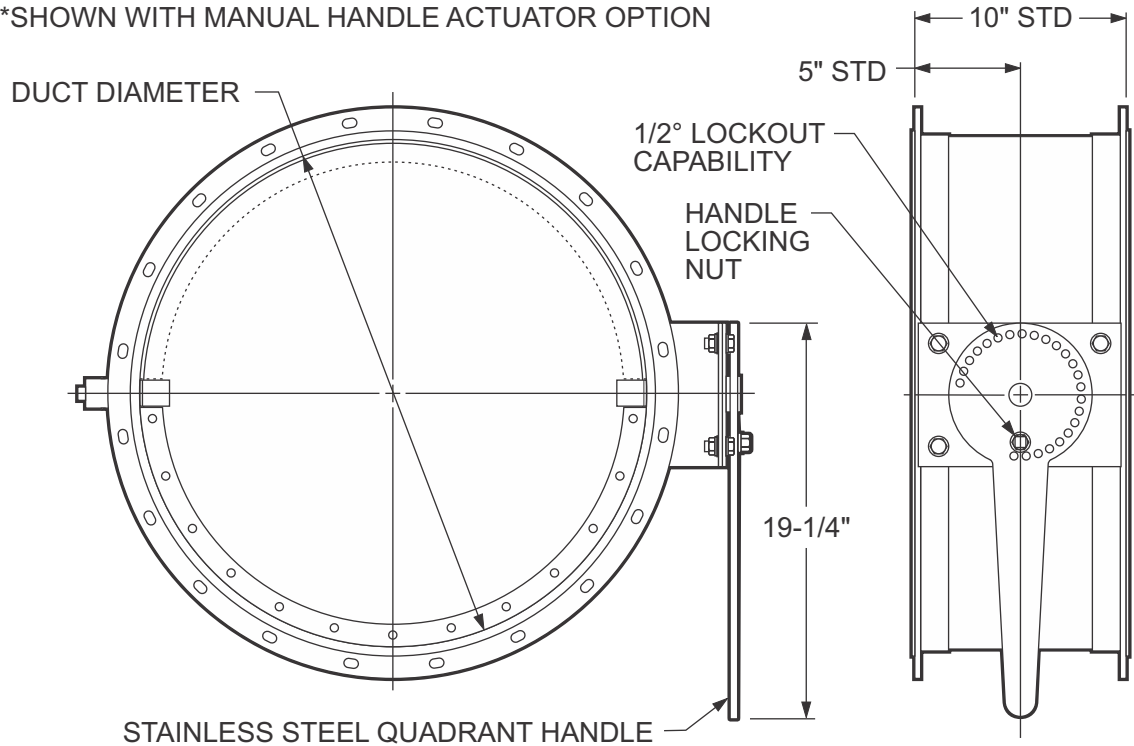

SPECIFICATIONS

Body:	Stainless steel body, rolled 12 GA fully fusion welded
Coating:	Components in contact with airstream coated with proprietary fluoropolymer barrier coating
Angle Rings:	Fully coated black iron rings, loose ring construction up to 30" diameter & stitch welded rings for 32" diameter and larger dampers - mounting holes straddle vertical centerline
Blade:	Stainless steel .250", opens CCW, Open/Close torque: 1000 in-lb recommended minimum
Axles:	Stainless steel 1.38" diameter
Quadrant:	Manual locking handle, all stainless steel construction with lockout capability in 1/2° intervals
Blade Stops:	Keyed fully welded blade stops
Bearings:	Nylon
Shaft Seals:	Thermoplastic liquid tight seals
Blade Seal:	Viton

OPTIONS

Actuators:	Manual gear drive / electric / pneumatic actuators
Mounting:	Blank mounting kit (plate & shaft adapter) for customer supplied actuator
Rings:	Stainless steel rings available, custom hole pattern

* Damper shown on cover: 24" diameter with loose black iron angle rings

Contact us today for more information:

Call: **802-655-8800**
 Fax: **802-655-8804**
 Website: **www.fabtechinc.com**
 Email: **sales@fabtechinc.com**



Fab-Tech, Inc.

A Critical Process Systems Group Company

Fab-Tech, Inc.
 480 Hercules Drive
 Colchester, VT 05446-6800 USA

PSP[®] is a registered trademark of Fab-Tech, Inc.
 Technical information contained in this document is subject to change without notice.