

18"-72" Vortex Damper

SPECIFICATIONS

- 10 GA. stainless steel body: 2-1/2" flanges
- 7/16" x 11/16" slotted mounting holes
- Mounting holes straddle vertical centerline
- 10 GA. stainless steel blades with overlap
- 1/2" diameter stainless steel blade axles
- Glass filled ETFE bearings
- Stainless steel linkages outside airstream
- 1/4" stainless steel drive ring
- 10 GA. stainless steel quadrant plate
- Hand actuated with micro adjustment and lockout feature

OPTIONS

- Pin-Lock Pin (Keyed MASTERLOCK[®] body sold separately)

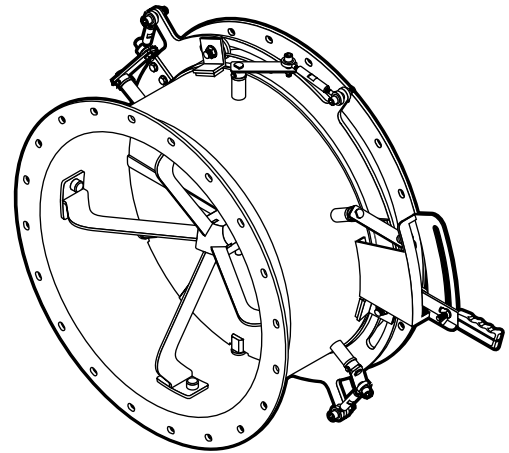

WITH JOINT SYSTEM

SS ANGLE RING	18" - 72"
---------------	-----------

