

50" & Larger Heavy Duty Industrial Damper

SPECIFICATIONS

- Stainless steel blade with stiffening ribs.
- Stainless steel body.
- Welded stainless steel rings.
- Gear drive actuator with lock out, 5° intervals.
- Mounting holes straddle vertical centerline.
- Welded blade stops.
- Liquid tight shaft seals, thermoplastic sleeve bearings.
- Available to 120" dia. - dampers larger than 84" dia. require engineering review & approval.

OPTIONS

- Pneumatic actuator.
- Electric actuator.
- Custom actuator mounting kit.
- Custom hole pattern.
- Pin-Lock Pin (Keyed MASTERLOCK[®] body sold separately)

OPEN/CLOSE TORQUE: 1600 in-lb
(RECOMMENDED MINIMUM)

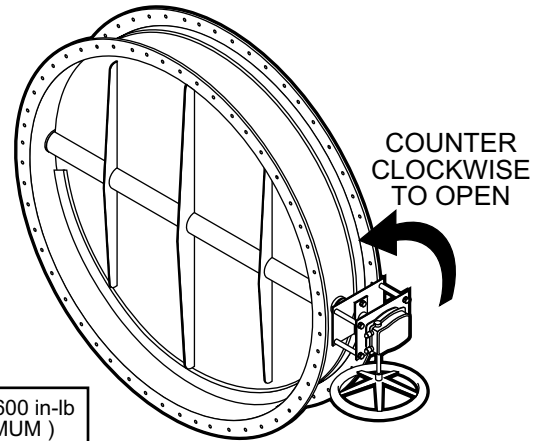

WITH JOINT SYSTEM

SS ANGLE RING | 50" - 120"

DIAMETER	BLADE	BODY
50" TO 84"	.38"	.25"

