

## 36"-48" AMCA Heavy Duty Industrial Damper

Fab-Tech, Inc. certifies that the Industrial Single Blade Isolation Damper shown herein is licensed to bear the AMCA Seal. The ratings shown are based on tests and procedures performed in accordance with AMCA Publication 511 and comply with the requirements of the AMCA Certified Ratings Program.

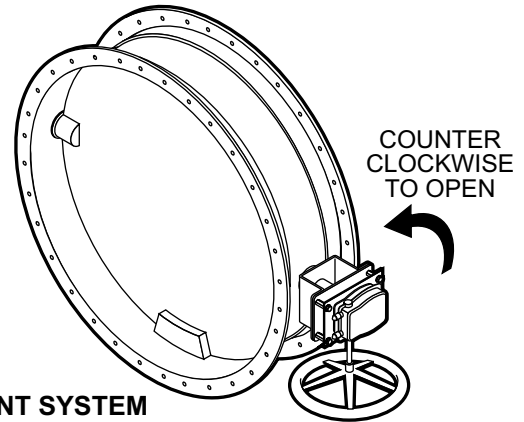

The AMCA Certified Ratings Seal applies to Air Leakage ratings and Air Performance ratings.

1. Test method per AMCA Standard 500-89

Data based on a seating torque of: 125 in-lbf/ft<sup>2</sup> for 16" damper, 86 in-lbf/ft<sup>2</sup> for 48" damper

2. Air leakage is based on operation between 50°F & 104°F (10°C to 40°C) and data corrected to represent standard air density 0.075 lbs/ft<sup>3</sup>.

Damper Dia.	Pressure	AMCA Leakage Class
36" - 48"	1" WG	1A
	4", 8", 12" WG	1

Tested Leakage Rates Available, Contact Fab-Tech Inc.

### Leakage Classification L/s/m<sup>2</sup> (ft<sup>3</sup>/min/ft<sup>2</sup>)

Pressure Class	Required Range		Extended Range (Optional)	
	0.25 kPa (1" wg)	1.0 kPa (4" wg)	2.0 kPa (8" wg)	3.0 kPa (12" wg)
1A	15.2 (3)*	N/A	N/A	N/A
1	20.3 (4)	40.6 (8)	55.9 (11)	71.1 (14)
2	50.8 (10)	102 (20)	142 (28)	178 (35)
3	203 (40)	406 (80)	569 (112)	711 (140)

\*Units for maximum ratings in ( ) are CFM Sq. Ft.

■ Damper Leakage Test based on ANSI/AMCA Standard 500-D-07, Ref. Fig 5.6

■ Pressure Drop Test based on AMCA Standard 500-D-98, Ref. Fig 5.3

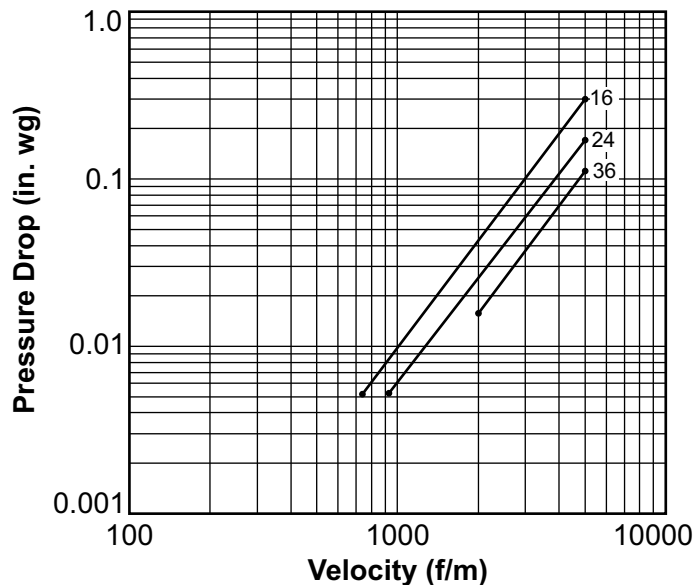

### WITH JOINT SYSTEM

BI ANGLE RING	36" - 48"
SS ANGLE RING	36" - 48"

OPEN/CLOSE TORQUE:  
1000 in-lb  
(RECOMMENDED MINIMUM)

### SPECIFICATIONS

- Welded stainless steel rings.
- Gear drive actuator with 5° damper axle lock.
- Mounting holes straddle vertical centerline.
- Liquid tight shaft seals - thermoplastic sleeve bearings.
- 1.38" stainless steel axles
- .25" stainless steel blades.
- Welded blade stops with Viton seal.

### OPTIONS

- Pneumatic actuator.
- Electric actuator.
- Custom actuator mounting kit.
- Custom hole pattern.
- Pin-Lock Pin ( Keyed MASTERLOCK® body sold separately )

DIAMETER	BLADE	BODY
36" TO 48"	.25"	10GA

