

Field Installed Nipple

DIE-CUT GASKET

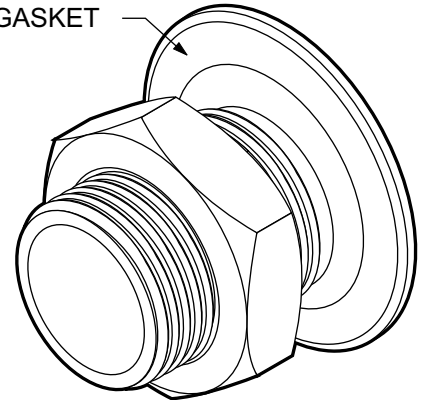

NOTES

- Refer to Fab-Tech's INSTALLATION AND ASSEMBLY GUIDE for assembly instructions.

PART NO.*	DESCRIPTION	MIN. HOST DUCT	MATERIAL THICKNESS
PRT01	1" NPT NIPPLE	6" DIA. DUCT MIN.	16 GA MAX MATERIAL THICKNESS
PRT15	1-1/2" NPT NIPPLE	8" DIA. DUCT MIN.	
PRT02	2" NPT NIPPLE	10" DIA. DUCT MIN.	

*PART NO. INCLUDES: (1) NIPPLE, (1) JAM NUT & (1) GASKET

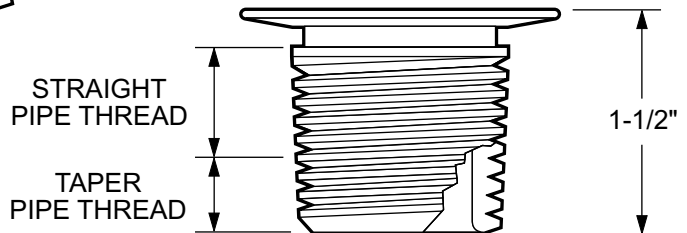
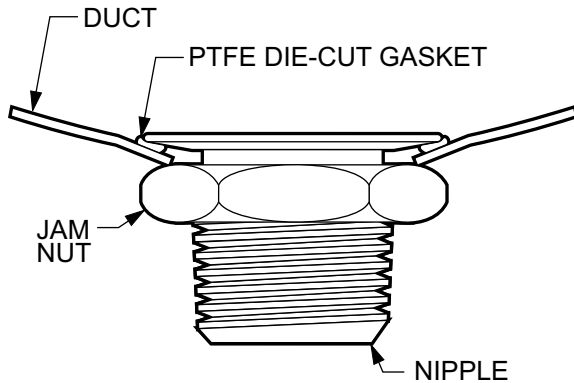

***SWAGE KIT REQUIRED TO INSTALL**
 ONLY ONE KIT REQUIRED TO INSTALL MULTIPLE NIPPLES

PART NO.*	DESCRIPTION
TPS01	MANUAL KIT FOR 1"
TPS02	HYDRAULIC KIT FOR 1", 1-1/2", & 2"