

**4" Industrial Isolation Damper**

**SPECIFICATIONS**

- Floating cast rings - stainless.
- PSP-EZ™ joining system.
- Manual actuation.
- Fluoroelastomer edge seal.
- Virgin Teflon blade.
- Liquid tight axle seals.
- Lockout feature - 5° intervals.

**OPTIONS**

- Micro-adjust actuator.
- Custom length.
- Custom hole pattern.
- Electric / pneumatic actuators.
- Pin-Lock Pin ( Keyed MASTERLOCK® body sold separately )

OPEN/CLOSE TORQUE: 250 in-lb  
( RECOMMENDED MINIMUM )

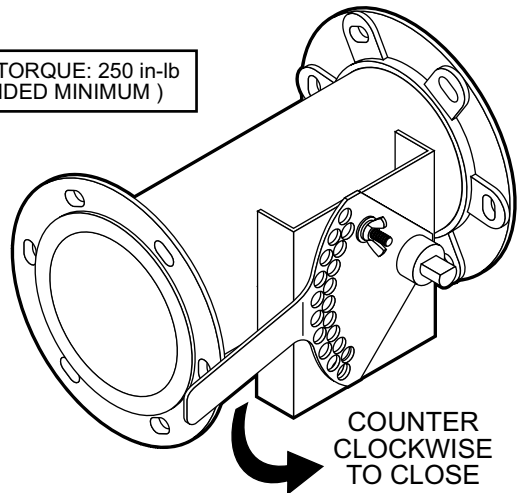

**WITH JOINT SYSTEM**

EZ CLAMP	4"
SS CAST RING	4"
BI ANGLE RING	4"

DIAMETER	BLADE	BODY
4"	TEFLON	20GA

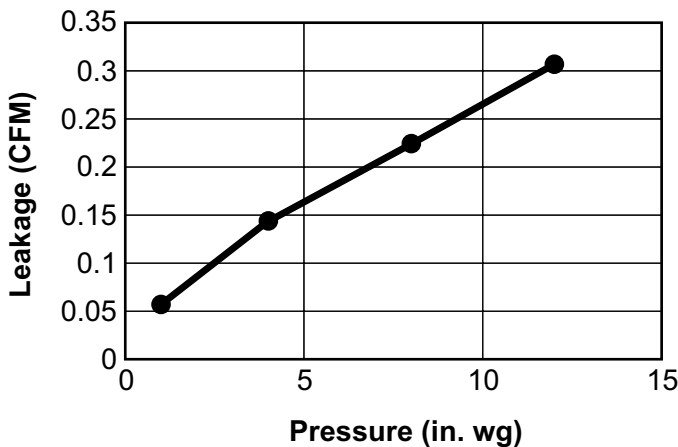

■ Damper Leakage Test based on ANSI/AMCA Standard 500-D-07, Ref. Fig 5.6

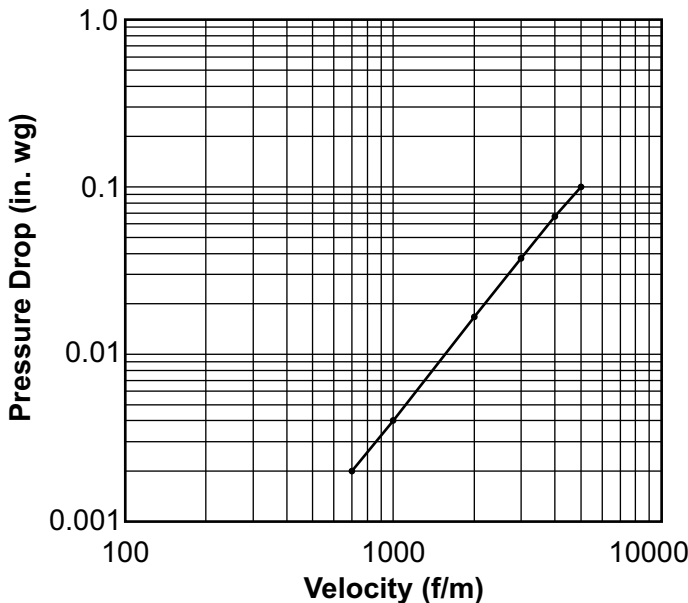

■ Pressure Drop Test based on AMCA Standard 500-D-98, Ref. Fig 5.3

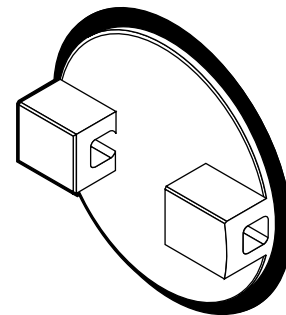

Virgin Teflon blade with fluoroelastomer edge seal

