

4"-14" Industrial Balancing Damper

SPECIFICATIONS

- Floating cast rings - stainless 4"-14".
- Floating rings - stainless steel or black iron 14".
- PSP-EZ™ joining system 4"-14".
- Manual actuation.
- PTFE blade 4" only.
- PTFE edge seal, 6"-14".
- Molded 25% glass filled PTFE blade holders.
- Liquid tight axle seals.
- Lockout feature - 5° intervals.

OPTIONS

- Micro-adjust actuator.
- Custom length.
- Custom hole pattern.
- Electric / pneumatic actuators.
- Pin-Lock Pin (Keyed MASTERLOCK® body sold separately)

DIAMETER	BLADE	BODY
4" TO 14"	10GA	20GA

OPEN/CLOSE TORQUE: 250 in-lb
(RECOMMENDED MINIMUM)

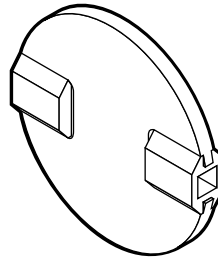
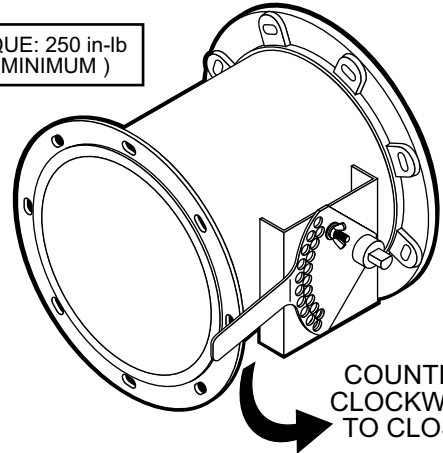

4" PTFE blade with
molded PTFE blade holders

WITH JOINT SYSTEM

EZ CLAMP	4" - 14"
SS CAST RING	4" - 14"
BI ANGLE RING	4" - 14"

OR A COMBINATION OF JOINING SYSTEMS

