

36"-48" Heavy Duty Industrial Sealed Bearing Single Blade Damper

SPECIFICATIONS

- Welded stainless steel rings.
- Gear drive actuator with 5° damper axle lock.
- Mounting holes straddle vertical centerline.
- Liquid tight shaft seals - thermoplastic sleeve bearings.
- 1.38" stainless steel axles - .25" stainless steel blades.
- Welded blade stops with Viton seal.

OPTIONS

- Pneumatic actuator.
- Electric actuator.
- Custom hole pattern.

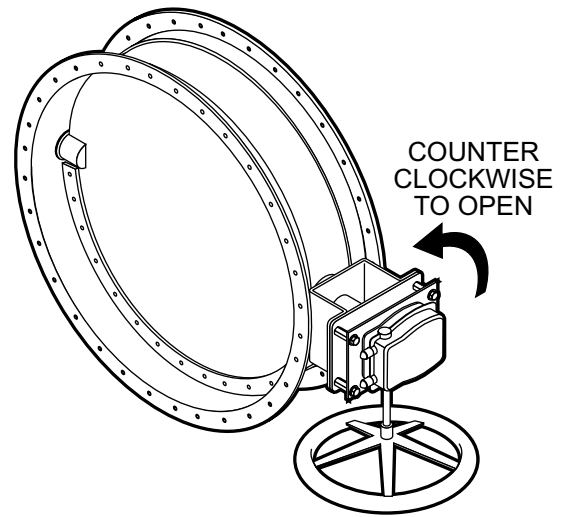

WITH ANGLE RINGS
(AVAILABLE 36" - 48")

DIAMETER	BLADE	BODY
36" TO 48"	.25"	10GA

