

4"-12" Wafer Single Blade Isolation Damper

SPECIFICATIONS

- BODY: Solid aluminum body, 1" width.
- BLADE: Coated 10GA stainless steel, machined PTFE blade for 4" damper only.
- EDGE SEALS: Viton extruded rubber.
- BLADE HOLDERS: Molded 25% glass filled PTFE.
- AXLES: Dual shaft, 1/2" diameter stainless steel.
- AXLE SEALS: Liquid tight - accommodate positive and negative system pressures.
- BEARINGS: Nylon.
- COATING: All components in contact with the airstream coated with fluoropolymer resin.
- QUADRANT: Manual locking handle, all stainless steel construction with lockout capability in 12° intervals.

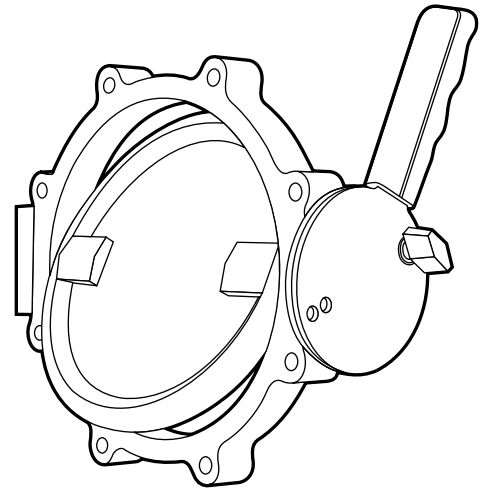

DIAMETER	BLADE	BODY
4" TO 12"	10GA	SOLID

BOLT HOLE SPECIFICATIONS

DUCT DIA "D"	NO. OF HOLES	BOLT HOLE SIZE	BOLT SIZE	BOLT CIRCLE DIA.
4	6	3/8	5/16	5.31
6				7.50
8				9.50
10	8	7/16	3/8	11.50
12				13.81

