

Gored Elbow

OPTIONS

- Standard gores and radii are shown, custom number of gores, custom radii, and throat extensions are available.
- Duct greater than 84" diameter requires Fab-Tech Engineering review and approval.

WITH JOINT SYSTEM

EZ CLAMP	4" - 14"
SS CAST RING	4" - 14"
BI ANGLE RING	4" - 94"
SS ANGLE RING	16" - 120"

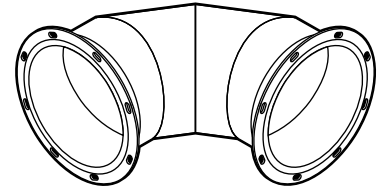

OR A COMBINATION OF JOINING SYSTEMS

90° ELBOW

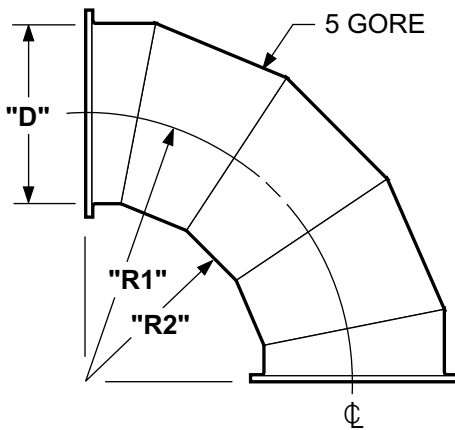

STANDARD RADIUS AT THE DUCT CENTERLINE

"R1" = 1.5 X "D"

STANDARD THROAT RADIUS

"R2" = "D"

LIMITATIONS

DUE TO MANUFACTURING LIMITATIONS, THE FOLLOWING FULL RADIUS ELBOWS ARE NOT AVAILABLE:

- 90° ELBOW GREATER THAN 56" DIA.
- 60° ELBOW GREATER THAN 82" DIA.
- 45° ELBOW GREATER THAN 106" DIA.

LARGE ELBOWS ABOVE THESE LIMITS WILL BE MANUFACTURED AS SMALLER FITTINGS.
EXAMPLE: AN 86" DIA. 90° ELBOW WILL BE SUPPLIED AS TWO 45° ELBOWS

FOR 1/2 RADIUS ELBOWS, THE FOLLOWING ARE NOT AVAILABLE:

- 90° ELBOW GREATER THAN 76" DIA.

ALSO DUE TO MANUFACTURING LIMITATIONS, MANY OF THE SMALLER 1/2 RADIUS ELBOWS WILL REQUIRE CAST RINGS OR FLAT RINGS.

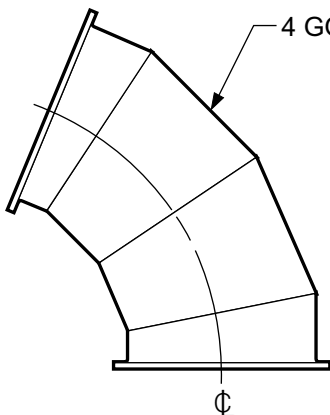

60° ELBOW

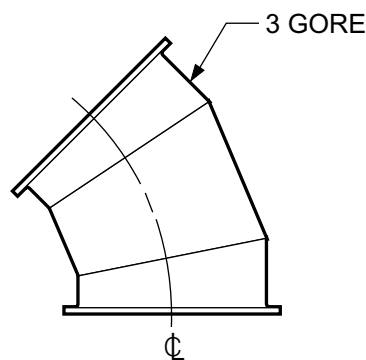

45° ELBOW

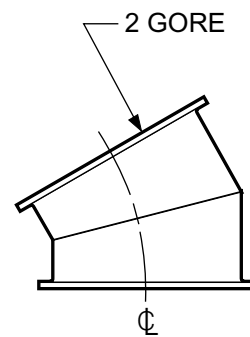

30° ELBOW