

**Gored Elbow**

**OPTIONS**

- Standard gores and radii are shown, custom number of gores, custom radii, and throat extensions are available.
- Duct greater than 84" diameter requires Fab-Tech Engineering review and approval.

**WITH EZ CLAMPS**  
(AVAILABLE 4" - 14")

**WITH CAST RINGS**  
(AVAILABLE 4" - 12")

**WITH ANGLE RINGS**  
(AVAILABLE 14" - 120")

**OR A COMBINATION OF JOINING SYSTEMS**

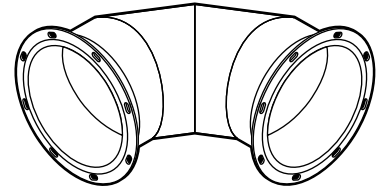

**90° ELBOW**

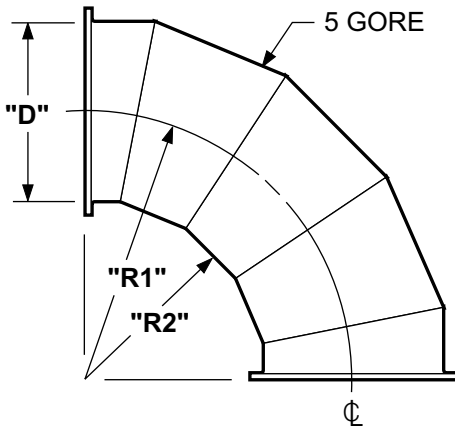

DUE TO MANUFACTURING LIMITATIONS, THE FOLLOWING ELBOWS ARE NOT AVAILABLE:

90° ELBOW GREATER THAN 56" DIA.  
60° ELBOW GREATER THAN 82" DIA.  
45° ELBOW GREATER THAN 106" DIA.

LARGE ELBOWS ABOVE THESE LIMITS WILL BE MANUFACTURED AS SMALLER FITTINGS.  
**EXAMPLE:** AN 86" DIA. 90° ELBOW WILL BE SUPPLIED AS TWO 45° ELBOWS

STANDARD RADIUS AT THE DUCT CENTERLINE

**"R1" = 1.5 X "D"**

STANDARD THROAT RADIUS

**"R2" = "D"**

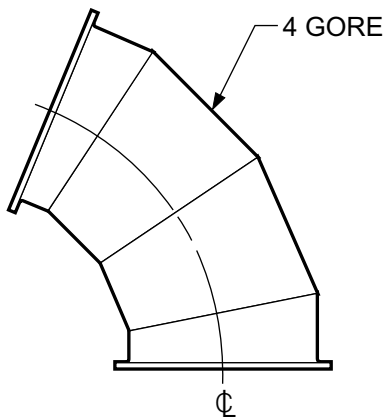

**60° ELBOW**

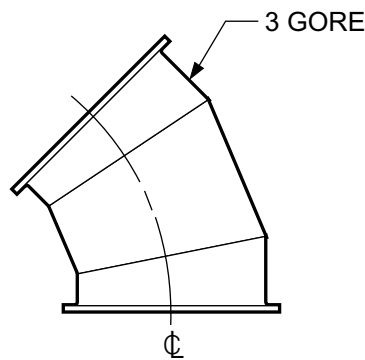

**45° ELBOW**

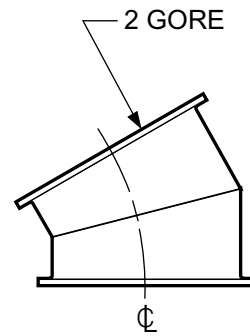

**30° ELBOW**