

Straight Duct with Lateral Tap

OPTIONS

- Custom lengths available.
- Raw end available.
- Multiple and offset taps available (see the multiple tap page).
- Duct greater than 84" diameter requires Fab-Tech Engineering review and approval.

WITH JOINT SYSTEM

EZ CLAMP	4" - 14"
SS CAST RING	4" - 14"
BI ANGLE RING	4" - 94"
SS ANGLE RING	16" - 120"

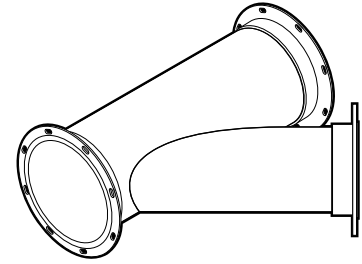

OR A COMBINATION OF JOINING SYSTEMS

OUR RECOMMENDATION IS TO ADD TAPS TO STANDARD 4' AND 8' STRAIGHT DUCT WHEN POSSIBLE - TAP DIMENSIONS SHOWN ARE MINS
 LONGER THAN STANDARD LENGTHS AND/OR HIGHER SYSTEM PRESSURES MAY REQUIRE ADDITIONAL STIFFENERS PER SMACNA, CONTACT FAB-TECH FOR SPECIFIC GUIDELINES.

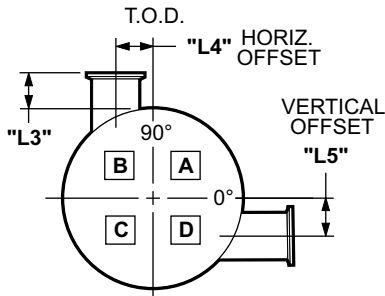

"D1" TAP OFFSET VIEW

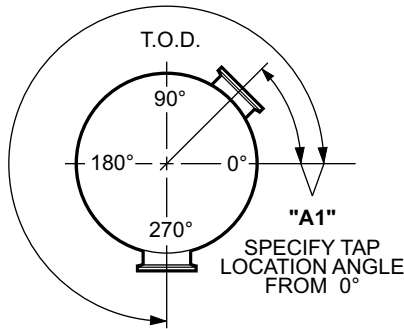

VIEW OF "D1" DUCT END

****L2 MIN DISTANCE**
 "D1" = 4" - 94": 4" MIN
 "D1" = 96" - 120": 5" MIN

***MIN LENGTH FOR "L3" AND "L4"**

"D1"	"L3"	"L4"
4" - 48"	6" MIN	4" MIN
50" - 58"	7" MIN	4" MIN
60" - 94"	8" MIN	5" MIN
96" - 120"	10½" MIN	6" MIN

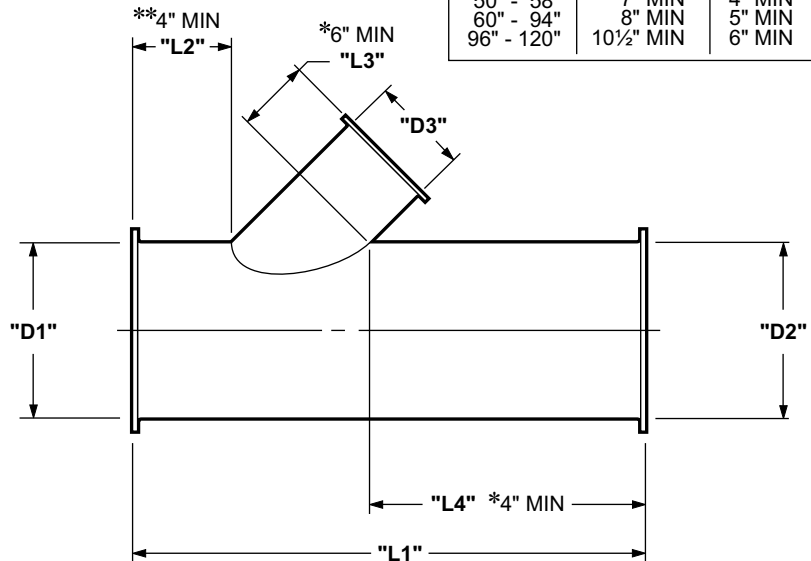

45° LATERAL TAP

"L1" MIN = ("D3" X 1.414) + 4" + "L4"
 (SEE MIN LENGTH CHART ABOVE FOR "L4")
 "L1" MAX = 96-1/4"
 "D3" MAX = 60"

LATERAL TAP GREATER THAN 60" ["D3"]
 REQUIRES 2 PIECE DESIGN
 AND ENGINEERING REVIEW

STANDARD DUCT LENGTHS ("L1")

JOINT SYSTEM	DIAMETER	"L1" (4')	"L1" (8')
EZ CLAMP / CAST RING	4" TO 14"	47.25"	
	8" TO 14"		95.25"
BLACK IRON ANGLE RING	4" TO 48"	47.25"	95.25"
	50" TO 94"	46.75"	94.75"
STAINLESS ANGLE RING	16" TO 48"	47.25"	95.25"
	50" TO 94"	46.75"	94.75"
	96" TO 120"	48.25"	96.25"