

# PermaShield<sup>®</sup>

Stainless Steel Corrosive  
Fume Exhaust System With  
PermaShield Fluoropolymer  
Barrier Coating

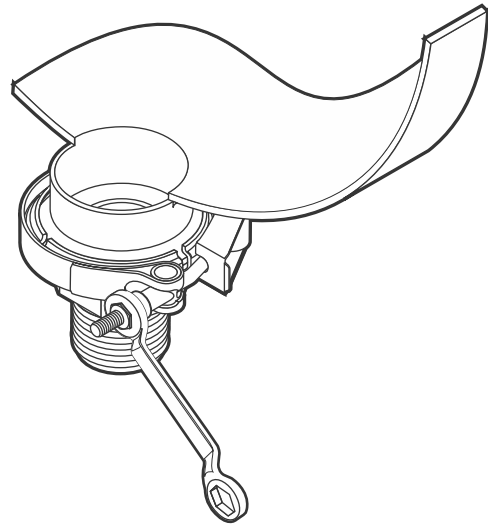

## INSTALLATION AND ASSEMBLY GUIDE

Catalog 04/20.6

**Fab-Tech**  
An Exyte Group Company

GENERAL	Introduction & General Informaiton _____	3
	PermaShield Duct Handling and Storage _____	4
	PermaShield Duct Mate to Other Duct Types _____	5
DUCT ASSEMBLY	PermaShield Companion Ring Duct Installation: 4" ( <i>101.6</i> ) and Larger _____	6
	EZ Installation: 4" ( <i>101.6</i> ) thru 14" ( <i>355.6</i> ) _____	9
	EZ Installation: 2" ( <i>50.8</i> ) and 3" ( <i>76.2</i> ) _____	11
FIELD MODIFICATIONS	PermaShield Duct Length Field Modfication: 4" ( <i>101.6</i> ) thru 22" ( <i>558.8</i> ) _____	12
	EZ Duct Length Field Modification: 2" ( <i>50.8</i> ) and 3" ( <i>76.2</i> ) _____	14
	Saddle Tap Field Installation (PermaShield and EZ Duct) _____	16
	Hot Tap Field Installation: 8" ( <i>203.2</i> ) thru 24" ( <i>609.6</i> ) _____	17
	Fab-Tech Flange Field Installation: 2" ( <i>50.8</i> ) _____	19
	Male Nipple Field Installation _____	21
	Test Port (Lollipop) Field Installation: 3/8" ( <i>9.5</i> ), 3/4" ( <i>19.1</i> ) & 2" ( <i>50.8</i> ) _____	24
	Fab-Tech Flange Assembly for Adapters _____	27
	Damper Actuator Field Installation _____	28
FIELD REPAIR	PermaShield Barrier Coating Repair _____	31
	Spark Test Protocol _____	32
CHARTS	Recommended Tooling _____	34

**METRIC EQUIVALENTS ARE SHOWN IN PARENTHESIS & ITALICS ( MILLIMETERS OR AS NOTED )**

## Introduction & General Info

### INTRODUCTION:

In 1991, Fab-Tech Incorporated formed a unique partnership with a leading fluoropolymer manufacturer to develop and manufacture a new generation of corrosive fume exhaust systems. The result of shared technologies was the creation of PermaShield products. PermaShield is a system that combines the structural integrity of stainless steel with the superior corrosion resistance of PermaShield Fluoropolymer Barrier Coating. PermaShield was crafted to meet the demanding safety standards of building and fire code officials as well as industry regulators and insurers.

PermaShield duct is designed and manufactured to withstand the effects of corrosive environments found in most fume removal systems. The coating process requires that very stringent manufacturing tolerances be maintained and that a high temperature, multi-bake process be used to achieve proper coating thickness and integrity.

PermaShield systems provide total ease of installation and maximum flexibility in the field. A significant feature of PermaShield contributing to the ease of installation is that our duct is FACTORY MUTUAL SYSTEM approved for fume and smoke evacuation without the use of sprinkler heads in the duct system. With proper handling and installation, you'll find the reliability of stainless steel with PermaShield Fluoropolymer Barrier Coating and PTFE gaskets will provide long term benefits and years of worry free productivity.

This guide is intended to aid you in the proper handling of our duct and to assist you in the assembly of the various types of joints necessary to maintain system integrity.

### DAMAGE AND LOSS:

Fab-Tech's responsibility for damage, loss or delay on shipments ceases on acceptance of shipment by the freight line. Any claim for such damages, loss or delay must be filed with the freight line by the consignee. Consignee must inspect the shipment upon delivery and note any and all damages or discrepancies on the bill of lading. Consignee has 15 days after receipt to notify the freight line of damage and 9 months to file such claims.

### DUCT JOINING SYSTEMS:

PermaShield duct and fittings are manufactured with either a bolted companion ring joining system or with a single fastener band-style clamping system.

#### Companion Ring Joining System

Cast Rings: 4" (101.6) to 14" (355.6) dia. (standard)  
Angle Rings: 4" (101.6) to 120" (3048.0) dia.

#### Band-Style Joining System

EZ: 2" (50.8) to 14" (355.6)

All joints use PermaShield Gasket 100% fully expanded PTFE gasket technology.

### COATING:

The PermaShield Fluoropolymer Barrier Coating is inspected at the factory. Sharp tools, operations that require grinding and dirt must be kept away from the duct at all times. PermaShield products rely on coated flange faces to provide a continuous corrosion barrier. Leave the packaging on the duct ends until just before installation.

### DAMAGED COATING:

Extreme care must be taken throughout the entire handling and installation process to protect the coating. During transportation or installation, the PermaShield coating may become scuffed and still be acceptable. A PermaShield fitting is deemed unacceptable when the coating has been damaged to the extent that the stainless steel has become visible and/or the duct fails at spark test (refer to the spark test procedure in this guide). An unacceptable fitting can usually, but not always, be repaired in the field. Repair instructions and kits are available by contacting the factory. Repair instructions are also included as part of this guide. Any damaged fitting that cannot be field repaired must be either factory repaired or discarded and replaced with a new PermaShield fitting.

### WARRANTY:

Any field installations or post installation operations must be performed using factory authorized procedures and accessories or the Fab-Tech warranty will be void.

**METRIC EQUIVALENTS ARE SHOWN IN PARENTHESIS & ITALICS (MILLIMETERS OR AS NOTED)**

## PermaShield Duct Handling &amp; Storage

**PROTECTION OF THE COATED SURFACE**

Proper handling and storage of PermaShield duct / fittings is crucial to a successful installation. While the stainless steel body can absorb a great amount of abuse, any coated surfaces must be handled with extreme care.

- If possible, transport fitting / control devices to installation site with all transportation packaging intact. All fittings are shipped with poly sheet over the ends to help prevent contamination and to protect the exposed outer coated surfaces of the flanges.
- Materials should not be stored in an area where the possibility of damage from traffic or debris may occur. If possible, store PermaShield duct indoors as additional protection from dirt and debris.
- Duct must not be stored on its flanges without some type of protective material ( pallets, corrugated cardboard, styrofoam or similar material ) on the coated faces to prevent damage to the coating.
- It is recommended that all coated surfaces be protected up to the point at which the gasket is installed before final fit up.
- Palletized or crated product should not be stacked, impacted, knocked or dropped.
- Pallets / crates containing PermaShield product should not be handled when the bolts securing the product to the base have been loosened or removed.
- Pallets are constructed to be lifted by a forklift with forks / fork extensions that are long enough to span the entire skid ( when lifting from the side ) or extend at least 60% of the length of the entire skid / crate ( when lifting from the end ).
- If such equipment is not available, then dragging or pushing the skid / crate slowly on a level surface is acceptable ( out of an enclosed trailer for example ).
- If it is necessary to move larger pieces by hand ( pieces too large to carry ), make sure to roll them on the angle rings to protect the coated flange faces from abrasive surfaces.
- When packaging is removed, extra care must be taken to prevent damage to the exterior surfaces and all coated areas. Avoid direct contact of the flange coating with asphalt or concrete and duct should never be dragged along the ground.

- EZ duct is shipped with tape gasket material pre-installed at the factory. To prevent possible damage to the gasket and the backing rings, this duct should always be staged or stored vertically. Since EZ duct joints use backing rings rather than stronger companion rings, the duct can compress out of round with moderate force which could cause the backing ring to become detached from the tape gasket.
- Take care to prevent contact between cutting tools and coated flanges. Tools should never come in contact with any coated surface.
- Under no circumstances shall welding or a heat source greater than 300°F (150°C) be allowed on the stainless steel surface of the duct.

**HANDLING****Care must be taken when transporting uncrated PermaShield Products**

- Estimated weights of fittings can be found in the Standards Section of the Catalog and control device estimated weight will be supplied upon request. Use proper lifting equipment to move larger PermaShield products.
- When moving fittings / devices, the part should be properly supported to prevent any bending of flanges, denting and scratches to the body of duct.
- Control devices require special care to avoid damage to housings or support structures.
- When lifting, the fitting or device must be uniformly supported to prevent bending of flanges and racking of control devices.
- Care must be used to prevent mechanical damage to the drive system ( motor or chain wheel, etc. ) on all control devices.
- When installing gear drive blast gates, the gate structure must be supported by the provided support lug or other support structure.
- For control devices equipped with limit switches, the open / closed limits must be re-verified before automated operation.

**METRIC EQUIVALENTS ARE SHOWN IN PARENTHESIS & ITALICS ( MILLIMETERS OR AS NOTED )**

## PermaShield Duct Mate to Other Duct Types

The joining of PermaShield duct to duct materials other than Fab-Tech's duct does not present any problems if handled properly.

### Flanged Joints - All Materials:

In almost all cases a flange can be added to other products already used for corrosive fume exhaust systems. Wall thickness for various products to be joined may vary. The minimum information required by Fab-Tech to manufacture a matching joint is the inside diameter (I.D.) of the existing duct, and the inside diameter (I.D.) and outside diameter (O.D.) of the flange to which PSP® is to be attached.

Flanges come in many different ratings and styles. When arranged by the buyer, Fab-Tech will make sure that bolt hole circles will match by providing a flange fabricated to the buyer's specifications. (Fig. 1)

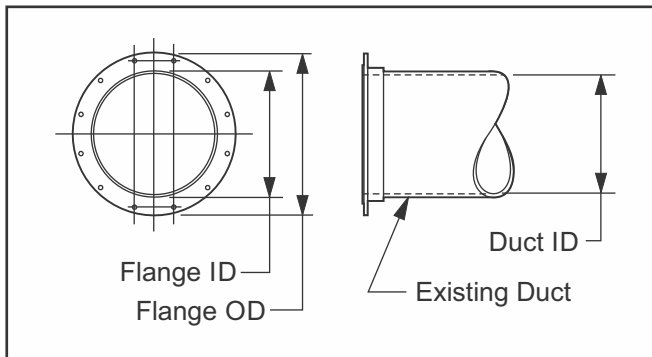
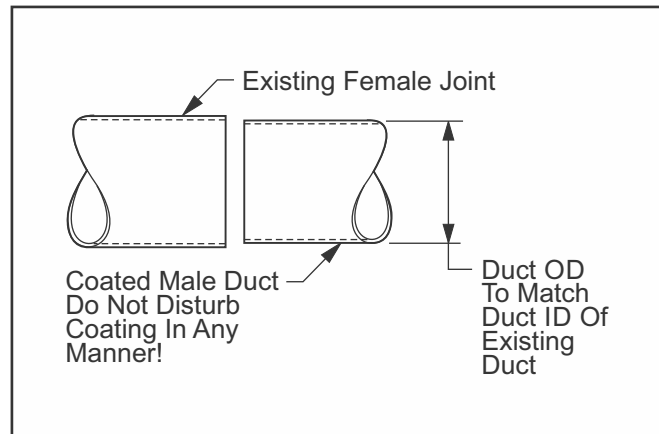

**Fig. 1:** Joining Dissimilar Flanged Materials

### Unflanged Joints - All Materials:

Fab-Tech can manufacture a fitting with a specified outside diameter (O.D.) or inside diameter (I.D.) that is to be used in a simple male / female joint. This PermaShield fitting will have either one end with an O.D. (male) that will be equal to the I.D. of the "existing" duct; or an I.D. (female) that will be equal to the O.D. of the "existing" duct.

If the "existing" duct is FRP, follow the procedures outlined by the FRP manufacturer for this type of connection with the exception that ***the PermaShield duct shall not have the end and/or coating roughened.*** ( Fig. 2 )



**Fig. 2:** Joining Dissimilar Unflanged Materials

**METRIC EQUIVALENTS ARE SHOWN IN PARENTHESIS & ITALICS ( MILLIMETERS OR AS NOTED )**

PermaShield Companion Ring Duct Installation 4" (101.6) and Larger

**GENERAL:**

The 4" (101.6) and larger bolted companion ring system has unique installation requirements. Companion rings are available in sizes from 4" (101.6) to 120" (3048.0). The minimum number of mounting holes for companion ring connections is one hole for each 4" (101.6) of duct circumference rounded up to the next higher number of holes. See the catalog for specific ring information. The standard configuration for companion ring joints varies with duct size. They are as follows:

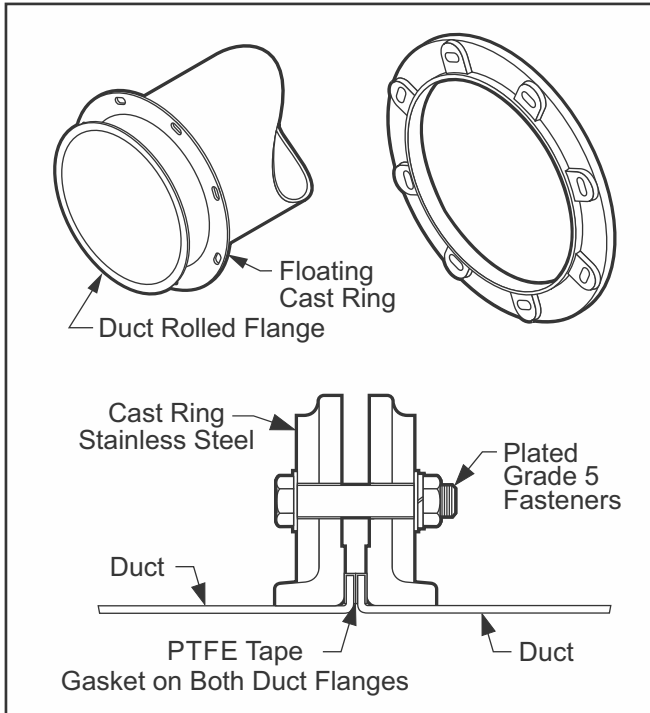

**Fig. 3:** Floating cast rings 4" (101.6) - 14" (355.6)

**4" - 14" PermaShield Floating Rings:**

Duct from 4" (101.6) to 14" (355.6) diameter with companion ring joints are manufactured with rolled duct flanges and either floating black iron angle rings or floating stainless steel cast rings. (Fig.3)

**16" - 30" PermaShield Floating Rings:**

Duct from 16" (406.4) to 30" (762.0) diameter with companion ring joints are manufactured with rolled duct flanges and floating black iron or stainless steel angle rings. (Fig. 4)

**32" - 120" PermaShield Fixed Rings:**

Duct in the 32" (812.8) to 120" (3048.0) diameter range are manufactured with rolled duct flanges and with the black iron or stainless steel angle rings stitch welded to the duct. The standard mounting hole locations for fixed angle rings straddle the vertical centerline unless otherwise specified. (Fig. 5)

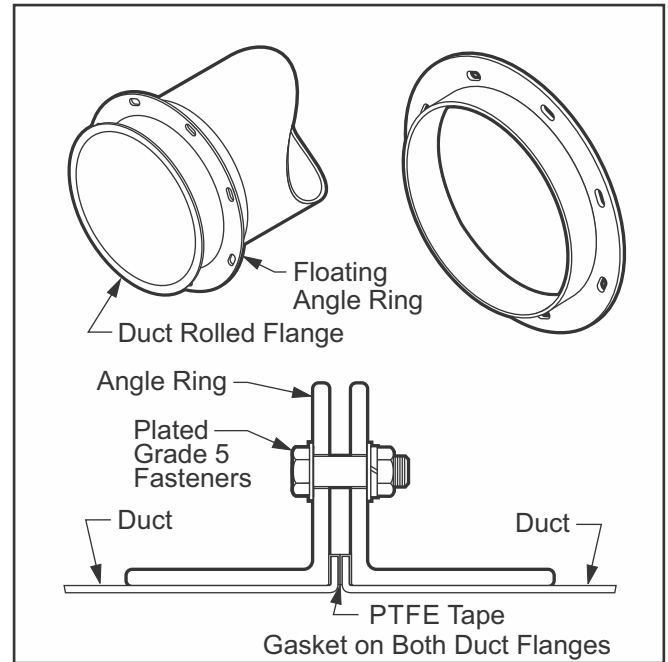

**Fig. 4:** Floating angle rings 16" (406.4) - 30" (762.0)

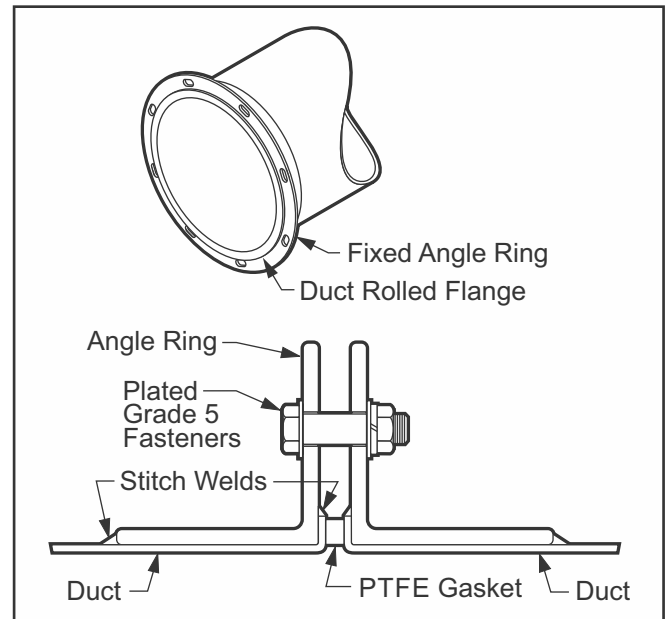

**Fig. 5:** Fixed angle rings 32" (812.8) - 120" (3048.0)

**Gaskets:** Standard PermaShield products are shipped with all gaskets required to complete the joints. The gasket material shall be form in place, fully expanded 100% PTFE joint sealant. Use care when matching the gaskets. Substituting other gaskets will void the warranty of the product. If a duct joint is disassembled for any reason, the gasket has been disturbed and must be replaced.

METRIC EQUIVALENTS ARE SHOWN IN PARENTHESIS & ITALICS (MILLIMETERS OR AS NOTED)

PermaShield Companion Ring Duct Installation 4" (101.6) and Larger

**GENERAL ( cont'd ):**

The gaskets for companion ring duct joints come in either loose bag lengths or on rolls. Please note that different types of gaskets are used for different diameters of PermaShield duct. (Fig. 6)

**PTFE GASKETS\* FOR RING JOINTS**

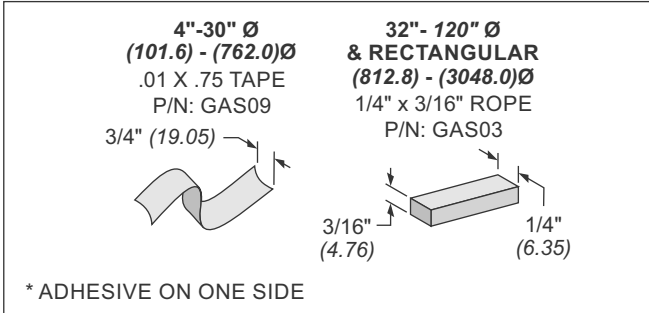

**Fig. 6:** Gasket size vs duct size

**Note:** Gasket Application Exceptions: Where standard gasket application is not possible; for example when joining an end cap to a standard duct flange in sizes below 32" (812.8) diameter there is no rolled flange face to apply GAS09 gasket take to the cap.

In this instance, use the exceptions table to identify the proper gasket application requirements. For this example; with a 14" (355.6) End Cap, apply GAS02 gasket over the duct flange GAS09 prior to assembly of the joint. (Fig. 7)

GASKET APPLICATION EXCEPTIONS		Gasket Application			
Product	Size Inches (mm)	GAS01	GAS02	GAS03	GAS09
Wafer Damper	4 (101.6) - 10 (254.0)	F*			F**
	12 (304.8) - 14 (355.6)		F*		F**
End Cap	4 (101.6) - 10 (254.0)	F*			F**
	12 (304.8) - 14 (355.6)		F*		F**
	16 (406.4) - 24 (609.6)		F		
	26 (660.4) - 30 (762.0)			F	
AMCA HVD Damper	16 (406.4) - 24 (609.6)		P		
HVD Damper					
Ultra Series Damper	26+ (660.4)			P	
Blastgate Actuated					

- P - Apply gasket on PRODUCT
- F - Apply gasket on adjoining FLANGE
- \* - Apply specified gasket on top of GAS09
- \*\* - Factory applied gasket

**Fig. 7:** Gasket application exceptions table

**Hardware:** PermaShield products are shipped with all the hardware required to complete the joints. The hardware shall be plated SAE Grade 5 fasteners. Use care when matching the hardware. Substituting other hardware will void the warranty of the product. Stainless steel fasteners are available on request but not recommended. Please note bolt and torque specifications vary with duct diameters. (Fig. 8)

**HARDWARE FOR RING JOINTS**

Torque Specs:		Grade 5 Bolt Markings:			
Torque in at least 3 stages					
Duct Dia.	Bolt Size	Bolt Mat'l	Ft lb	In lb	Nm
4"-10" (101.4-254.0)	3/8" (9.53)	Gr.5 *SS	35	420	48
			25	300	34
**12-14" (304.8-355.6)	3/8" (9.53)	Gr.5 *SS	35	420	48
			25	300	34
12"-120" (304.8-3048.0)	1/2" (12.7)	Gr.5 *SS	65	780	88
			60	720	82

\* STAINLESS STEEL HARDWARE REQUIRES APPLICATION OF ANTI-SEIZE LUBRICANT PRIOR TO ASSEMBLY. LOCKTITE LB771 OR EQUAL.  
\*\* REQUIRED FOR RINGS WITH 7/16" DIAMETER BOLT HOLES.

**Fig. 8:** Hardware size and torque specs vs duct size

**PROCEDURE:**

**TOOLS REQUIRED:**

- Low torque air or electric wrench
- Socket wrenches
- Box wrenches
- Cutting tool
- Calibrated torque wrench
- Lint free cloth

**1. Inspect Duct:** All companion ring pieces are shipped with poly sheeting over the ends to help prevent contamination and to protect the outer surface of the duct flange/ring. Carefully remove the poly sheeting and inspect the interior coated surface and the outer flange surfaces to insure the integrity of the system. Wipe away any dust and debris using a soft lint free cloth. Do not, under any circumstances, install a piece of duct or fitting that has visible damage. Do not penetrate the coating for any reason except when using approved modification systems. Gasket tape is pre-installed on 4" (101.6) - 14" (355.6) duct.

**2. Cut Flange Gasket:** If pre-cut gasket lengths are not provided for 32" (812.8) - 120" (3048.0) duct, cut rope gaskets to the correct length by wrapping the gasket around the duct and adding approximately 2"

**METRIC EQUIVALENTS ARE SHOWN IN PARENTHESIS & ITALICS (MILLIMETERS OR AS NOTED)**

PermaShield Companion Ring Duct Installation 4" (101.6) and Larger

**PROCEDURE (cont'd)**

(50.8) to the length for overlap. Only one gasket is required for each joint.

**3. Install Gasket 4" (101.6) - 30" (762.0):** If the duct or fitting joint already has gasket tape applied, skip this step. Otherwise, the PTFE gasket is now applied which comes as an adhesive backed tape. Slide the floating ring a comfortable distance away from the duct rolled flange. Peel back the adhesive backing paper. Start (A) by firmly pressing the adhesive side of the tape to the rolled flange edge first at an angle tangent to the duct opening. Holding the end of the tape firmly in place, continue applying the tape (B) by pulling and tacking it along the edge of the duct rolled flange. There will be enough width to the tape to be able to press the tape about equal amount onto the front and back sides of the rolled flange. To complete this process (C), overlap the tape ends 1/2" (12.7) to 1" (25.4). Then firmly press the tape onto the rolled flange front and back to guarantee complete adhesion. Ensure about 80% of the front or outward flange surface area is covered with sealant tape for best mating joint. Slide the floating ring back against the rolled flange for duct installation. (Fig. 9)

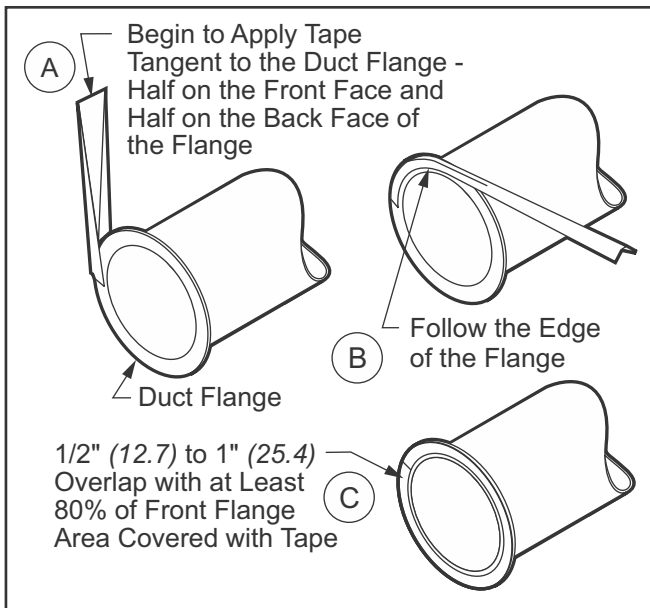

**Fig. 9:** Apply gasket for 4" (101.6) to 30" (762.0) duct

**4. Install Gasket 32" (812.8) - 120" (3048.0):** To start installation, snap the gasket to peel the backing near one end. Press the exposed adhesive side of the gasket firmly onto the angle ring below one of the holes at the top to the ring. Smoothly adhere the gasket around the outside edge of the rolled duct flange. Overlap the end between 1" (25.4) and 2" (50.8) just

below the beginning bolt hole and continue up next to the hole before trimming. Again, run a finger along the gasket to seat the adhesive. (Fig. 10)

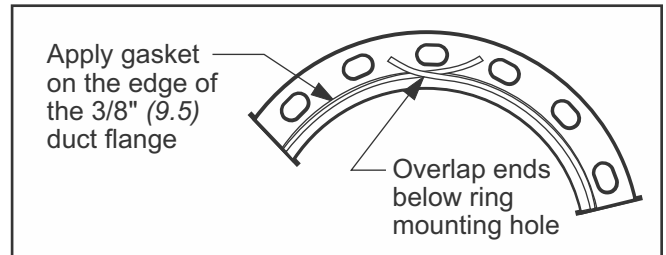

**Fig. 10:** Gasket installation for floating & fixed rings

**5. Install Hardware:** Care must be taken not to disturb the gasket during duct joint positioning. Bring the duct ends directly into place without shifting side to side and start a few bolts on opposite sides of the ring.

Check the alignment of the duct sections and when satisfied, install the remaining fasteners. Each bolt should be installed with a flat washer beneath the bolt head and a flat washer against the ring on the nut end with a lock washer between the nut and the flat washer. Tighten all fasteners finger tight. (Fig. 11)

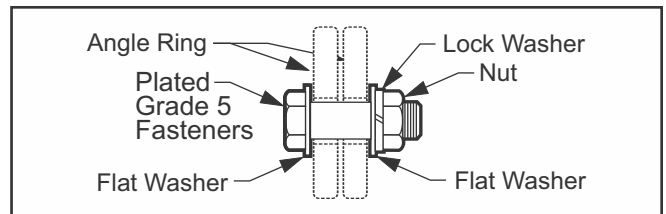

**Fig. 11:** Angle ring hardware configuration

**6. Torque Hardware:** Hardware must be torqued in the following sequence to evenly distribute pressure on the gasket material and flange rings. Utilizing a low torque air/electric wrench or hand tools tighten the flange bolts in an alternating star pattern to 30% of the listed torque value. The following steps shall be carried out with a calibrated torque wrench in a circular pattern around the ring. Tighten the flange bolts to 60% of the listed torque value. Adjust the torque wrench to 100% of the listed torque value and again tighten the bolts in a circular pattern. Passing by the first bolt in the torque sequence, verify that the first few bolts require no additional twist to reach 100% torque value. If bolt twist is observed, continue in a circular sequence until no further bolt twist occurs. Fab-Tech recommended torque values are listed in: (Fig. 8).

**7. End of Procedure:**

**METRIC EQUIVALENTS ARE SHOWN IN PARENTHESIS & ITALICS ( MILLIMETERS OR AS NOTED )**



## EZ Duct Installation: 4" (101.6) - 14" (355.6)

**GENERAL:**

The EZ clamp system has unique installation requirements. EZ duct is available in sizes from 2" (50.8) to 14" (355.6) and the standard configuration varies with duct size. The standard configuration for 4" (101.6) to 14" (355.6) EZ joints is as follows:

**4" (101.6) to 14" (355.6) EZ:** Duct from 4" (101.6) to 14" (355.6) EZ joints are manufactured with duct flanges, floating EZ backing rings and utilize single fastener band style clamps. The clamps shall provide a minimum compression load to the gasket of 900 psi (6205 kPa). (Fig. 12)

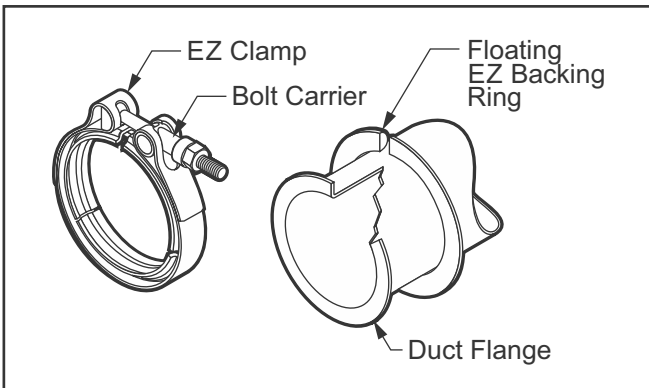

**Fig. 12:** 4" (101.6) - 14" (355.6) EZ configuration

**Gasket:** 4" (101.6) thru 14" (355.6) EZ duct and fittings are shipped with gasket tape applied at the factory. The gasket material (PermaShield Gasket) shall be in place, fully expanded 100% PTFE joint sealant. Each joint requires gasket tape on both mating duct and/or fitting flanges. Substituting other gaskets will void the warranty of the product. If an EZ joint is disassembled for any reason, the gasket has been disturbed and must be replaced.

**PROCEDURE:****TOOLS REQUIRED:**

7/16" (11.1) Box Wrench  
 Low Torque Power Driver  
 7/16" (11.1) Deep Socket Driver  
 Calibrated Torque Wrench  
 Lint Free Cloth  
 Locking Pliers

**1. INSTALL GASKET:** If the duct or fitting joint already has gasket tape applied, skip this step. To begin, slide the backing ring firmly against the flange. The PTFE gasket is now applied which comes as an adhesive backed tape. Start (A) by applying the tape to the flange surface first at an angle tangent to the duct opening. Firmly press the tape onto the flange. There will be enough width to the tape so that you will be able to press the tape onto the back side of the backing ring. Holding the end of the tape firmly in place, continue applying the tape (B) by pulling and tacking it along the edge of the backing ring. To complete this process, (C) overlap the tape ends 1/2" (12.7) to 1" (25.4). Then go back and firmly press the tape onto the flange and backing ring to guarantee complete adhesion. The gasket tape has a secondary function of holding the backing ring firmly against the flange. Make sure that at least 80% of the flange surface area is covered with the sealant tape. (Fig. 13)

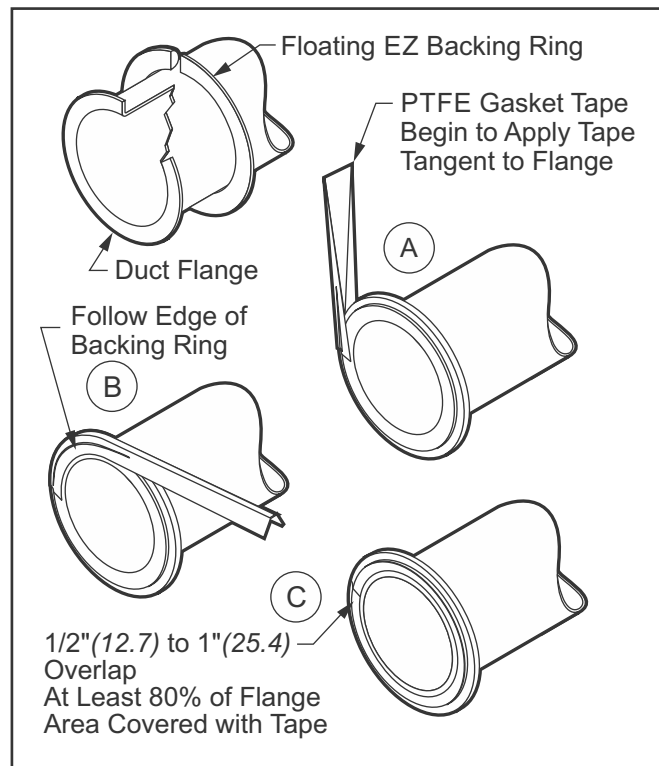
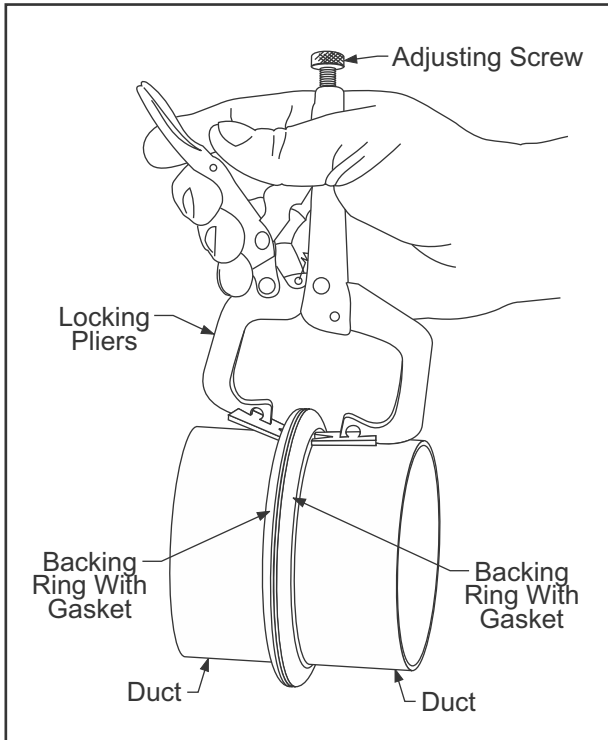

**Fig. 13:** Apply gasket for 4" (101.6) - 14" (355.6) EZ duct

**2. BRING FLANGES TOGETHER:** Carefully bring together the two flanges to be joined. Duct support hangers are the best method for aligning duct prior to installation. Secure this positioning using special locking pliers. (Fig. 14)

**METRIC EQUIVALENTS ARE SHOWN IN PARENTHESIS & ITALICS (MILLIMETERS OR AS NOTED)**

**PROCEDURE (cont'd):**



**Fig. 14:** Secure duct alignment with locking pliers

Duct Dia.	Bolt Size	Torque Specifications: Torque in at least 3 stages		
		lb*ft	lb*in	kg*m
2", 3", 4", 6" <i>(50.8, 76.2, 101.6, 152.4)</i>	1/4" <i>(6.35)</i>	6.25	75	0.9
8", 10", 12", 14" <i>(203.2, 254.0, 304.8, 355.6)</i>	5/16" <i>(7.9)</i>	10	120	1.4

**Fig. 15:** Hardware size and torque specifications

**3. INSTALL CLAMP:** Using both hands, open the clamp and carefully slip the clamp onto the backing rings so that the "V" shaped groove in the clamp accepts each round surface of the backing rings. When the clamp is fully engaged around the entire circumference, insert the clamp bolt through the carrier and start the locknut on the bolt.

**4. TIGHTEN CLAMP:** Using a 7/16" (11.1) wrench or low torque power drive, tighten the clamp by tightening the nut on the clamp fastener until the clamp just starts to grip the gasket. Although this method of joining duct is self aligning, visually inspect the joint to ensure proper alignment of the flanges and proper seating of the backing rings in the clamp. Remove the locking pliers. Tighten the clamp until resistance to further tightening is felt.

**5. TORQUE BOLT:** When satisfied with the alignment, tighten the clamp bolt to the specified torque with a calibrated torque wrench. (Fig. 15)

**6. END OF PROCEDURE:**

**METRIC EQUIVALENTS ARE SHOWN IN PARENTHESIS & ITALICS (MILLIMETERS OR AS NOTED)**

## EZ Duct Installation: 2" (50.8) and 3" (76.2)

**GENERAL:**

The 2" (50.8) and 3" (76.2) sizes of the Fab-Tech EZ clamp system have unique installation requirements. All pieces are shipped in poly sheeting to help prevent contamination and to protect the outer surfaces of the flange. Remove the pieces from the poly sheeting and inspect the interior coated surface and the outer flange surfaces to insure the integrity of the system. Do not, under any circumstances, install a piece of pipe or fitting that has visible damage. Do not penetrate the coating for any reason except when using approved modification systems.

The standard configuration for 2" (50.8) and 3" (76.2) EZ joints is as follows: EZ fittings and Fab-Tech Flange System adapters are only manufactured in 2" (50.8) and 3" (76.2) diameter sizes. These fittings are manufactured with machined EZ rings welded to the ends of the duct or fitting and utilize single fastener band style clamps. (Fig. 16)

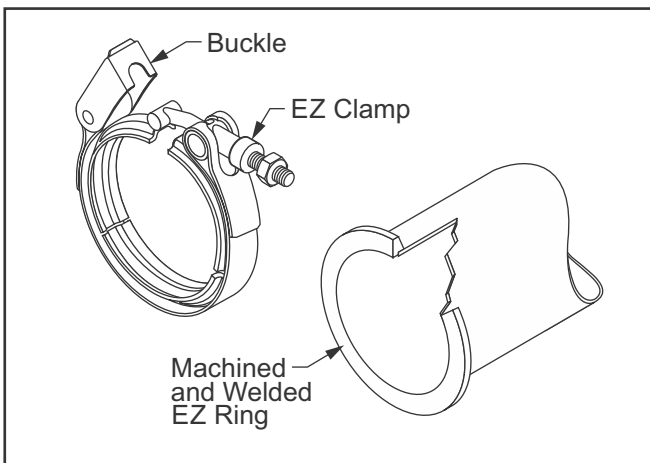

**Fig. 16:** 2" (50.8) & 3" (76.2) EZ configuration

**Gasket:** 2" (50.8) & 3" (76.2) EZ duct and fittings are shipped complete with all gaskets to complete the joints. The gaskets used are an adhesive backed die-cut type. Only one die-cut gasket is required for each joint. The gasket material (PermaShield Gasket) shall be in place, fully expanded 100% PTFE joint sealant. Substituting other gaskets will void the warranty of the product. If an EZ joint is disassembled for any reason, the gasket has been disturbed and must be replaced.

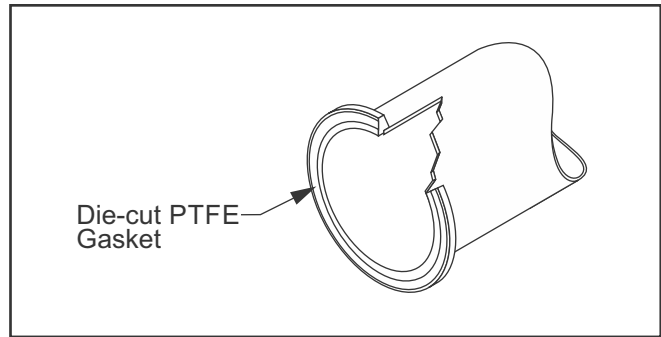

**Fig. 17:** Apply gasket for 2" (50.8) & 3" (76.2) EZ duct

**PROCEDURE:****TOOLS REQUIRED:**

7/16" (11.1) Box Wrench  
 Low Torque Power Driver  
 7/16" (11.1) Deep Socket Driver  
 Calibrated Torque Wrench  
 Lint Free Cloth

**1. APPLY GASKET:** Always use a new gasket. Peel the backing from the die-cut gasket and adhere it approximately centered to one of the flanges. Adhere the gasket to the flange that is already in the system if possible. Smooth the gasket with a finger to seat the adhesive fully after final positioning. Only apply one gasket per joint. (Fig. 17)

**2. BRING FLANGES TOGETHER:** Loosen and thread the nut on the clamp to the end of the bolt. Unclasp the buckle on the clamp and slightly pull the clamp apart. Install the clamp on the stationary piece. Then bring the piece you are installing into the clamp. This will take some practice.

**3. TIGHTEN CLAMP:** When both angle flanges are trapped under clamp band, reattach the buckle onto the clamp bolt and tighten the clamp nut until the duct sections stay together.

**4. TORQUE BOLT:** When satisfied that the alignment of the clamp and pieces are correct, tighten the clamp nut until resistance to further tightening is felt in the bolt. Final tightening must be done with a calibrated torque wrench. The 2" (50.8) and 3" (76.2) clamp bolts are 1/4" (6.35) and are torqued to: 75 in-lbs (6.3 ft-lbs or 0.9mkg).

**5. End of Procedure:**

**METRIC EQUIVALENTS ARE SHOWN IN PARENTHESIS & ITALICS (MILLIMETERS OR AS NOTED)**

## PermaShield Duct Length Field Modification: 4" (101.6) thru 22" (558.8)

**GENERAL:**

PermaShield duct can be shortened in the field. This can be done to duct sections that are constructed of 18GA (1.27) material or lighter. For companion ring duct, the range of sizes able to be shortened is from 4" (101.6) to 22" (558.8). For EZ duct, the range of sizes able to be shortened is from 4" (101.6) to 14" (355.6).

**PROCEDURE:****TOOLS REQUIRED:**

Marking Pen  
Flexible Ruler  
Drill  
Center Punch  
Double Cut Power Shear  
Flat File  
Flanging Tool - Pexto model 622  
1/8" Drill Bit  
Step Drill

**1. MEASURE THE DUCT:** Measure the installation for the desired section length. (Fig. 18) Transfer this measurement to the duct section to be shortened. Add 3/8" (9.5) to the measured length to allow for the flange height. Mark this measurement in several places around the duct circumference. Connect these marks using a marking pen and flexible ruler.

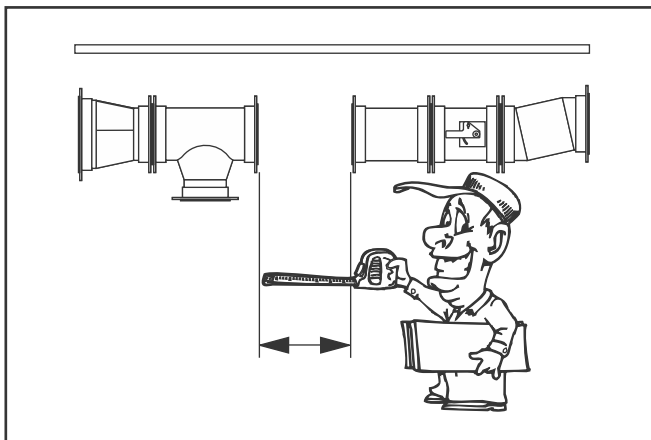

**Fig. 18:** Measure for modification

**2. SLIDE RING:** For companion ring duct, carefully slide the floating ring back along the duct beyond the cutting guide line. For EZ duct, carefully remove the gasket tape from the backing ring and also carefully

the backing ring back along the duct beyond the cutting guide line. This is to ensure that the companion ring or backing ring doesn't interfere with the cutting and flanging operation.

**3. CUT DUCT:** Drill a 3/8" (9.5) to 1/2" (12.7) hole just tangent to the scrap side of the cutting line. First, mark the location for the starter hole and center punch the location. Drill a starter hole using the 1/8" (3.2) drill. Enlarge this pilot hole in small steps using a step drill. Proceed slowly so that a minimum of heat is generated, as excessive heat can damage the coating. Insert a power shear, double cut recommended, at this hole and cut as accurately as possible on the scrap side of the line.

**4. SMOOTH EDGES:** Using a file, remove all sharp edges from the cut. Be careful that the end of the file does not damage the coating.

**5. FLANGE TOOL SETUP:** Assemble tool per the manufacturer's directions. (Fig. 19) The rolls must be clean, undamaged and burr free. Any metal filings, chips, dirt or abrasive material will damage the coating. Roll flanges in a clean work site that is not near any grinding or welding operations. The gold colored rolls are custom rolls supplied by Fab-Tech. These rolls are ground smooth and hardened to provide an accurate and burr free surface to work the coating during the flanging process.

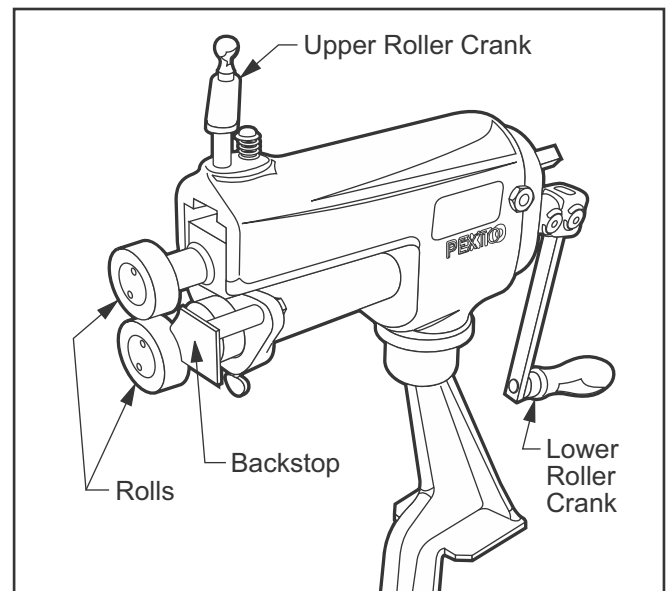

**Fig. 19:** Flanging Tool Setup

**METRIC EQUIVALENTS ARE SHOWN IN PARENTHESIS & ITALICS (MILLIMETERS OR AS NOTED)**

## PermaShield Duct Length Field Modification: 4" (101.6) thru 22" (558.8)

**PROCEDURE (cont'd):**

**6. SET FLANGE HEIGHT:** Once the backstop is installed, it should be adjusted to slightly more than 3/8" (9.5) depth from the roll faces and locked in place. This dimension sets the height of the flange. We recommend that you experiment with some scrap pieces of duct to make sure the setting is producing the flange height desired. Fab-Tech generally uses a 3/8" (9.5) flange height. The tolerance for this flange height varies for the EZ and PermaShield companion ring joint types. If the piece will be used with a ring flange, the tolerance is  $\pm 1/16"$  (1.6). If the joint has a clamp, the flange should not be higher than 3/8" (9.5) but it is allowed to be 1/16" (1.6) less, or 5/16" (7.9) high. This tolerance is important to the function of the clamped system. A quick check for correct flange height for clamped joints can be done by using an aluminum backing ring as a checking gage. (Fig. 20)

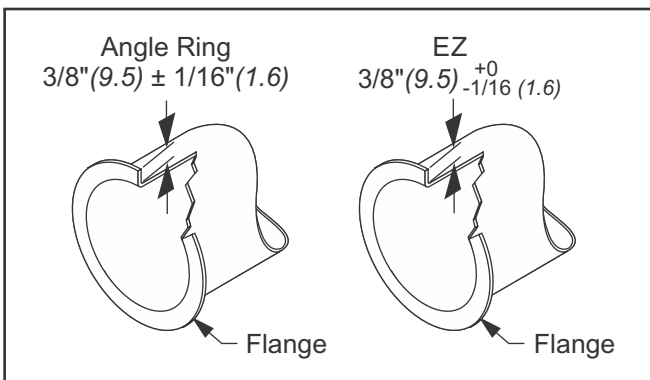
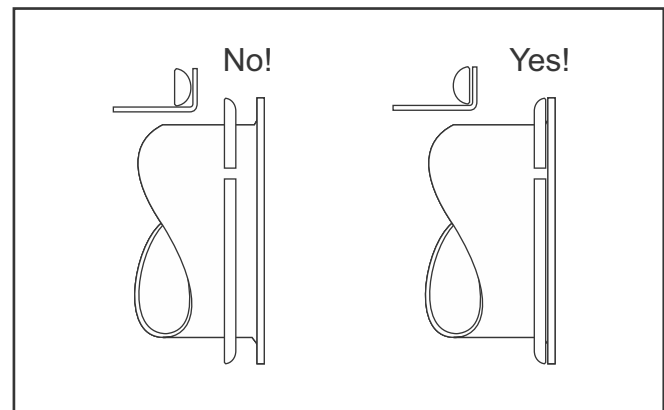

**Fig. 20:** Flange Height Dimensions & Tolerances

**7. FLANGE DUCT END:** Place the cut end of the duct on the lower roller and slide the duct up against the backstop. Lower the upper roller with the smaller crank located on the top of the tool. Tighten the rolls to slightly pinch the duct between the rollers. Do not over tighten the rollers as this can damage the coating. Crank the large handle with one hand while steadying the duct section with the other hand to flare the duct wall. Slight upward pressure on the duct while cranking will begin to crease the metal at the face of the upper roller. Continue around the duct slowly until the flange is turned to an appropriate degree where the balance can be completed with a clean plastic, rawhide or rubber mallet. Place a clean cloth over the flange before using the mallet to provide added protection for the coating. Loosen the rollers and remove the duct from the tool.

**8. SPARK TESTING:** Follow the appropriate spark test protocol as noted in this guide.

**9. INSTALL GASKET:** For PermaShield duct, slide the companion ring up against the new flange. Apply gasket as required, only one gasket is required per joint for companion ring joints. For EZ duct, slide the backing ring up against the new flange. If installing a new backing ring, make sure that the round face of the ring is positioned away from the duct flange. (Fig. 21) Once the EZ backing ring is in place, apply PTFE gasket as noted in this guide. The shortened duct section is now ready to be installed.

**10. END OF PROCEDURE:**

**Fig. 21:** EZ Backing Ring Position

**METRIC EQUIVALENTS ARE SHOWN IN PARENTHESIS & ITALICS (MILLIMETERS OR AS NOTED)**

EZ Duct Length Field Modification: 2"Ø (50.8) and 3"Ø (76.2)

**PROCEDURE:**

**TOOLS REQUIRED:**

- Ridgid Pipe Cutter - Size 1" (25.4) - 3" (76.2)
- Rawhide Mallet or "Dead Blow" Hammer
- Fab-Tech Part #D0700, Pressing Wheel Adapter
- Vise or Pipe Stand
- Flat File
- Lint Free Cloth

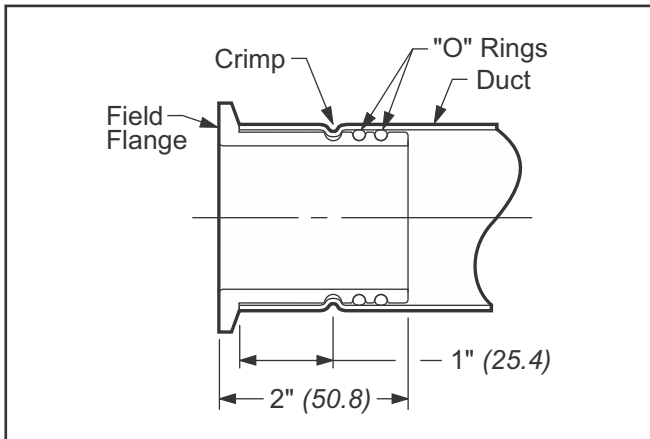

Fig. 22: EZ Field Flange Configuration

**FOR USE ON EZ STRAIGHT DUCT ONLY, NOT DESIGNED FOR 2" (50.8) & 3" (76.2) EZ ELBOWS, TEES OR REDUCERS.**

**1. MEASURE DUCT:** Sometimes it is necessary to shorten a section of 2" (50.8) or 3" (76.2) EZ duct at the installation site. Measure the installation for the desired duct section length. To allow for the thickness of the adapter flange, you must subtract 1/4" (6.4) from this measurement to arrive at the proper cut length. Mark this calculated measurement on the outside diameter of the duct section to be cut. It is recommended that you also mark which end of the duct is to be discarded to avoid confusion later.

**2. CUT THE DUCT:** Use of a pipe miter box to cut the duct is recommended, cut must be square. Do not use a pipe cutter. Also, do not use power tools to make this cut as the heat generated by the power tool will damage the coating. Use the correct size cutting guide to ensure that the cut will be square and flat. These guides hinge around the duct and then clamp into a vise holding the duct securely. It may help to measure the width of the guide and make a second mark. Make

sure that the slot in the cutting guide is positioned on the proper cut length before processing. Use a fine tooth hacksaw blade to cut using the slot in the cutting guide. When complete, remove the duct pieces from the guide and vise.

**3. SMOOTH EDGES:** Smooth the sharp edges of the cut, paying particular attention to smoothing the inside edges. Be careful not to damage the coating with the end of the file. Wipe away filings with a clean cloth.

**4. INSTALL FIELD FLANGE:** The flange adapter requires two "O" rings that are installed in the two outer grooves in the barrel behind the flange. The inside groove is used for the crimping operation. Insert the adapter into the end of the duct. Make sure the adapter, duct and "O" rings are clean and undamaged. Using a clean plastic or leather mallet, gently drive the adapter into the stop at the back of the flange. Use a clean cloth as additional protection on the end of the flange. DO NOT use a steel hammer. (Fig. 23)

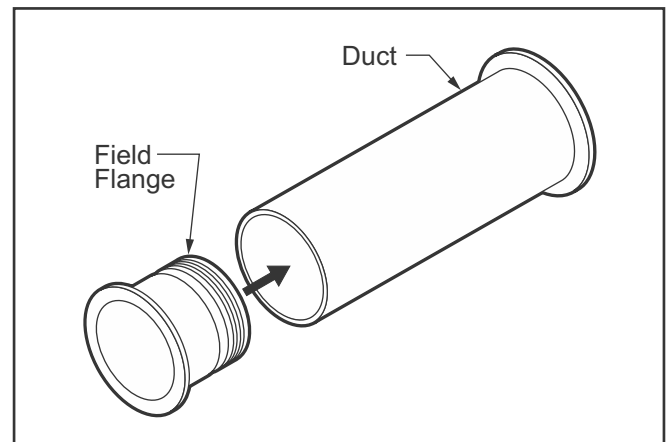

Fig. 23: Install Field Flange

**5. MODIFY PIPE CUTTER:** The pressing tool is a standard pipe cutter with a modified wheel. The Fab-Tech D0700 pressing wheel is installed in place of the standard cutter wheel. This custom roller wheel is installed on a press fit shaft. To change from the cutter wheel to the roller, you must drive the shaft out with a drift pin. Only drive the pin far enough to remove the cutter, then align the roller with the shaft and drive the shaft back into position. The head of the shaft has flats that align with a slot in the casting.

**METRIC EQUIVALENTS ARE SHOWN IN PARENTHESIS & ITALICS ( MILLIMETERS OR AS NOTED )**

## EZ Duct Length Field Modification: 2"Ø (50.8) and 3"Ø (76.2)

**PROCEDURE (cont'd):**

**6. CRIMP DUCT:** Measure back from the cut end of the pipe at 1" (25.4). Make several marks around the duct at this measurement. Open the pipe cutter so that it fits over the pipe. Align the custom roller with the marks on the duct section. Tighten the pipe cutter using the large clamp screw handle until it just makes an impression in the metal at the tip of the roller.

**7. CRIMP DUCT:** Then rotate the tool around the pipe making a shallow groove. The first pass should be very slight in depth. This operation is to make sure that the roller is following a straight line around the pipe. When a complete crimp impression is made, tighten again with the screw and crank to deepen the crimp. Use multiple passes to form a bead 1/32" (.79) deep minimum. When the crimp is complete, the clamp screw will get very difficult to tighten. When complete, loosen the clamp screw and remove the tool. (Fig. 24)

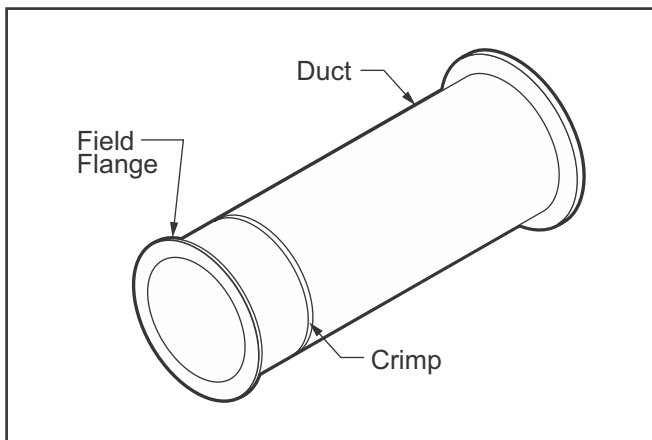

**Fig. 24:** EZ Field Flange Crimp

8. END OF PROCEDURE:

**METRIC EQUIVALENTS ARE SHOWN IN PARENTHESIS & ITALICS ( MILLIMETERS OR AS NOTED )**

Saddle Tap Field Installation

**PROCEDURE:**

**TOOLS REQUIRED:**

- Center Punch
- Marking Pen
- Power Shear
- Calibrated Torque Wrench
- Flat File
- Lint Free Cloth

It is recommended that two persons are available to do this installation, at the discretion of the project manager, depending on the size of the fitting and the location of the branch line at the host duct. Check that all required material is available at the work location.

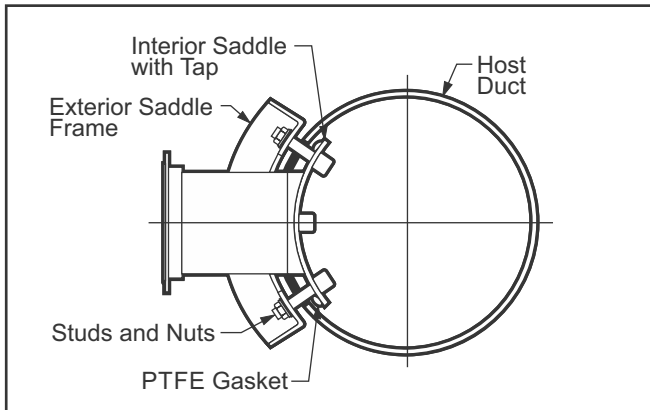
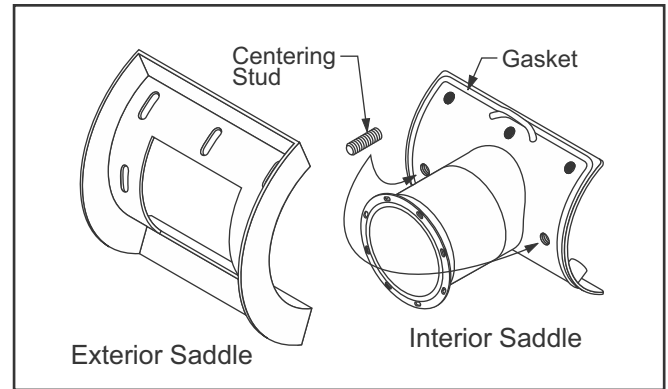

**Fig. 25: Saddle Tap Configuration**

**1. CUT OPENING:** Trace the template which is provided with the saddle tap onto the host duct. Use a center punch to mark the pilot holes which are drilled on each corner of the template. Drill larger holes in each corner to accommodate the power shear. Cut opening in the host duct and carefully file the edges of the cut. If it is necessary to preserve the air pressure in the system, cut a thin sheet of galvanized steel 2" (50.8) larger than the dimension of the template and place over the hole.

**2. INSTALL INTERIOR SADDLE:** Apply PTFE gasket to the outside edge of the interior saddle, as shown. Slip the interior saddle carefully into the opening. With the saddle in place, insert studs finger tight into the two horizontal center holes. (Fig. 26)

**3. INSTALL EXTERIOR FRAME:** Set the exterior frame over the tap, locating the slots over the two exposed centering studs. Place flat washer, lock washer and nut onto each center stud, lightly tighten. This will position the saddle tap temporarily in place.



**Fig. 26: Interior and Exterior Saddles**

**4. POSITION TAP:** Install studs along the bottom horizontal edge of the interior saddle. Finger tighten. Reposition the tap by gently pulling down on the tap until the bottom studs contact the raw edge of the host duct opening. Now tighten the two horizontal center nuts to draw the saddle halves together.

**5. INSTALL HARDWARE:** Install studs in all remaining holes of the interior saddle. Finger tighten. Visually inspect that the saddle tap is in position and that the gasket can make full contact with the interior of the host duct. Place flat washer, lock washer and nut onto each of the studs, lightly tighten.

**6. TORQUE NUTS:** Using a calibrated torque wrench, tighten the two center horizontal nuts to recommended torque specifications (8 ft-lbs (10.8 Nm) minimum for 5/16" (7.9) bolts, 15 ft-lbs (20.3 Nm) minimum for 3/8" (9.5) bolts, torque in at least 3 stages until specified torque is reached). Continue tightening all the other nuts to recommended specifications, moving evenly away from the center nuts to prevent distortion of the saddle against the host duct. On larger duct, tighten from the center of all four sides of the saddle. Leave the corner studs as the last ones to tighten. The saddle tap is now ready to use.

**7. END OF PROCEDURE:**

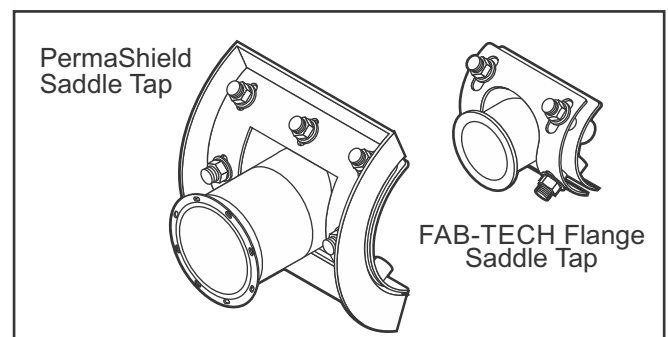

**Fig. 27: PermaShield and EZ Saddle Taps**

**METRIC EQUIVALENTS ARE SHOWN IN PARENTHESIS & ITALICS (MILLIMETERS OR AS NOTED)**



Hot Tap Field Installation: 8" (203.2) - 24" (609.6)

**GENERAL:**

The field installed 4" (101.6) to 24" (609.6) diameter hot tap is unique in that it allows for a PermaShield tap fitting to be installed in a live duct system ranging in size from 12" (304.8) diameter and larger without costly shutdown of the system and disruption in production. See the tap to host duct matrix below to find the correct size tap for your system.

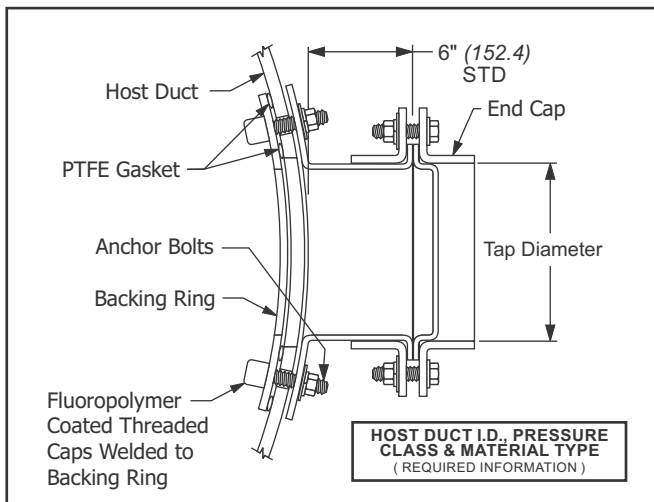

Fig. 28: Hot Tap - Section Through Duct

**PROCEDURE (cont'd):**

**TOOLS REQUIRED:**

- Metal Cutting Jig Saw with Carbide Saw Blade
- Electric or Pneumatic Drill - Drill bit 5/16" (7.9)
- Permanent Marker
- Center Punch
- Duct Tape
- Allen Wrench
- Glove Box (required) with Pressure Plate
- Torque Wrench and Socket

**1. POSITION TAP TEMPLATE:** Place the hot tap template on the duct at the desired location. Position template such that the tab and alignment bolt hole are located at the bottom of the desired location.

**2. TRACE TEMPLATE:** Trace the hot tap hole and alignment bolt hole onto the duct using a permanent marker. Also mark the line the approximate horizontal centerline position of the hot tap on the duct.

**3. PUNCH:** Center punch and drill the alignment bolt hole and a starter hole just above the tab for cutting the hot tap opening.

**4. CUT TAP OPENING:** Use a metal cutting jig saw to cut the hot tap opening. Slide the pressure plate over the hot tap hole and under the hot tap cutout as it is being cut to maintain system pressure.



**5. POSITION GLOVE BOX:** Using the hot tap horizontal centerline markings from Step 2, position the glove box on the duct over the hot tap pressure plate and hold in place with duct tape.

**6. POSITION TAP BACKING RING:** Lift the plexi-glass viewing window and place the hot tap backing ring and the alignment bolt inside the glove box and close the viewing window. Insert hands into the gloves and hold the backing ring. Have a second person slide the pressure plate out of the way. Position the backing ring inside the duct to align with the curvature of the duct.



**METRIC EQUIVALENTS ARE SHOWN IN PARENTHESIS & ITALICS (MILLIMETERS OR AS NOTED)**

Hot Tap Field Installation: 8" (203.2) - 24" (609.6)

**PROCEDURE (cont'd):**

Also align the bottom bolt hole on the backing ring with the alignment hole on the tab and thread the alignment bolt into the backing ring to temporarily secure the backing ring, use the allen wrench to tighten the bolt.



**7. REMOVE GLOVE BOX:** Slide the pressure plate over the hot tap opening using the slot at the bottom of the pressure plate to align with the alignment bolt. Remove the glove box from the duct.

**8. POSITION HOT TAP:** Slide the hot tap with attached end cap onto the alignment bolt using the bottom bolt hole on the tap and carefully remove the pressure plate out from under the hot tap.



**9. INSTALL ANCHOR BOLTS:** Insert 3/8" (9.5) anchor bolts into the hot tap mounting holes and thread the bolts into the backing ring inside the duct. Slide a flat washer and lock washer onto each anchor bolt and thread a nut finger tight onto each anchor bolt. Use an allen wrench to remove the alignment bolt and replace with an anchor bolt and hardware.

**10. TIGHTEN BOLTS:** Torque all bolts to 36 ft-lbs (48.8 Nm). Installation is complete.

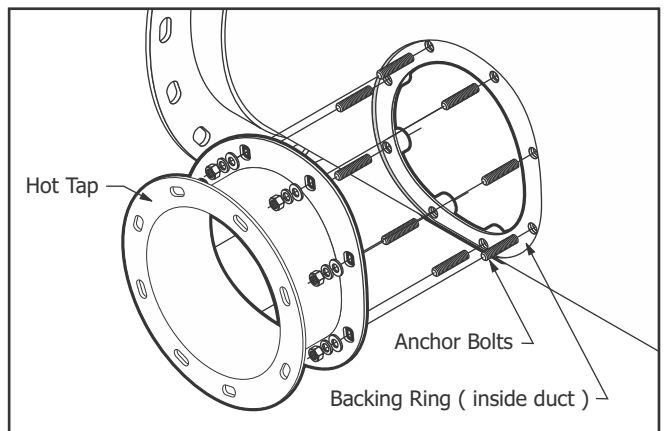

Fig. 29: Hot tap basic assembly.

**11. END OF PROCEDURE:**

**View the complete installation video that these screen shots were taken from at: [www.fabtechinc.com/literature](http://www.fabtechinc.com/literature)**

**METRIC EQUIVALENTS ARE SHOWN IN PARENTHESIS & ITALICS (MILLIMETERS OR AS NOTED)**

## Fab-Tech Flange Field Installation

### GENERAL:

The Field Installed 2" (50.8) Fab-Tech Flange has unique installation requirements. In order for this fitting to be installed, the duct section must be removed from the system or installed before the duct section is placed in the system. This fitting is available in only 2" (50.8) size with specific requirements for the host duct as indicated below. Once installed, 2" (50.8) EZ and modular flange system fittings can be attached to this field installed flange.

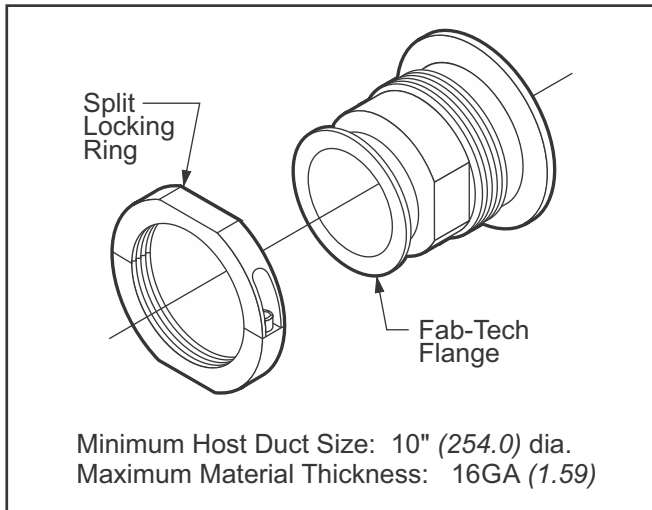

**Fig. 30:** Field Installed 2" (50.8) Fab-Tech Flange

### PROCEDURE:

#### TOOLS REQUIRED:

Hydraulic punch kit (Fab-Tech PN TPS02)  
 Electric or pneumatic drill  
 Drill bit set  
 Lint free cloth

**1. DRILL PILOT HOLE:** Drill a 3/8" (9.5) pilot hole in the duct at the desired location of the test port.

**2. 3/4" (19.1) PUNCH:** From the Hydraulic punch kit thread the 3/8" (9.5) stud into end of 3/4" (19.1) draw stud of the Greenlee hydraulic actuator. Slide the three spacers onto the 3/4" (19.1) actuator draw stud. Slide the 3/4" (19.1) die onto the 3/8" (9.5) stud with the open end of the die facing away from the actuator. Insert the 3/8" (9.5) stud through the 3/8" (9.5) pilot hole. From

inside the duct thread the matching 3/4" (19.1) punch onto the 3/8" (9.5) stud with the cutting surfaces of the punch toward the duct. Continue threading the punch by hand until the die, duct and punch are snug. Operate the hydraulic actuator to draw the punch through the duct material. Remove the punch, die, 3/8" (9.5) stud and spacers. (Fig. 31)

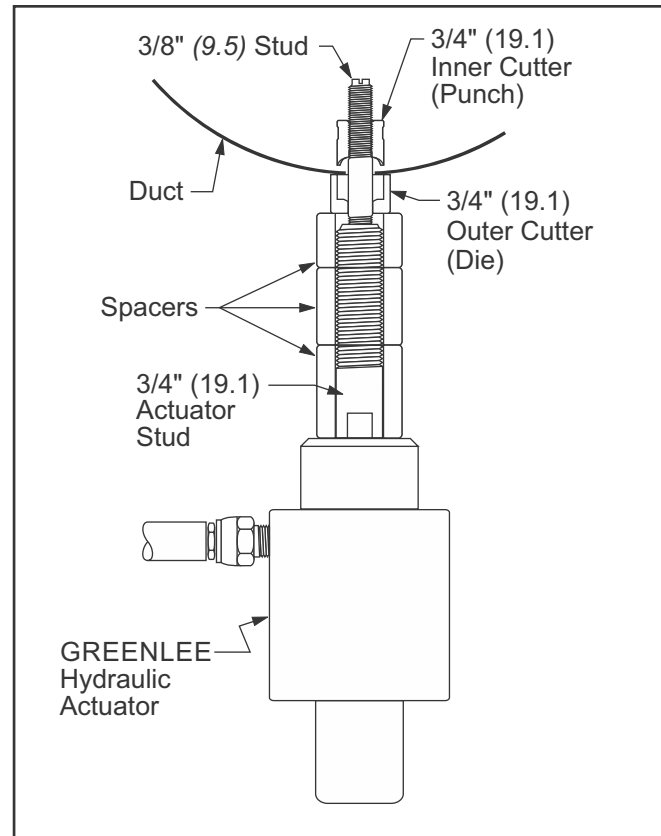

**Fig. 31:** 3/4" (19.1) Hydraulic Punch Configuration

**CAUTION:** Support the actuator and punch assembly during this operation. The punch assembly will drop out of the newly formed hole once it breaks through the duct material.

**3. 60mm PUNCH:** Slide the 60mm die ( for 2" (50.8) test port) onto the 3/4" (19.1) actuator stud with the open end of the die facing away from the actuator. Insert the 3/4" (19.1) actuator stud into the 3/4" (19.1) hole. From inside the duct thread the matching 60mm punch onto the 3/4" actuator stud with the cutting surfaces of the punch toward the duct. Continue threading the punch by hand until the die, duct, and punch are snug. Operate the hydraulic actuator to draw the punch through the duct material. Remove the punch and die. (Fig. 32)

**METRIC EQUIVALENTS ARE SHOWN IN PARENTHESIS & ITALICS (MILLIMETERS OR AS NOTED)**

Fab-Tech Flange Field Installation

**PROCEDURE (cont'd):**

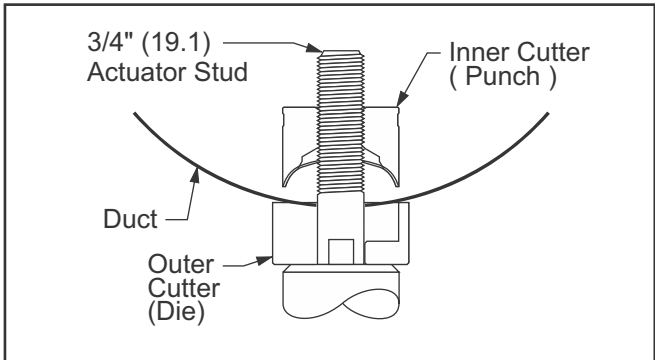

Fig. 32: 60mm Hydraulic Punch Configuration

**4. SWAGE HOLE:** Slide the 60mm outer swage tool onto the 3/4" (19.1) actuator stud. Insert the actuator stud and outer swage tool into the 60mm hole. From inside the duct slide the matching inner swage tool onto the actuator stud. Invert and thread any one of the three punches onto the actuator stud (cutting surfaces facing away from the inner swage tool) until the inner swage tool, the duct and the outer swage tool are snug. Operate the hydraulic actuator to compress the swage tools together to form the swage. Loosen and remove the swage tool. (Fig. 33)

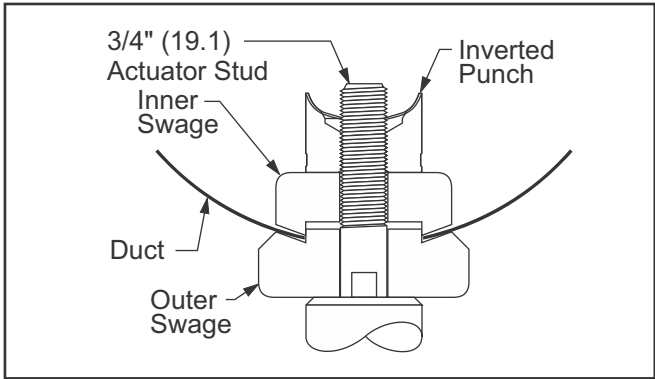

Fig. 33: 60mm Swage Configuration

**5. INSTALL FAB-TECH FLANGE:** Remove the backing and apply die-cut PermaShield Gasket to the inside flange of the fitting. Place the fitting in the swaged hole from inside the duct so that the gasket forms a seal between the inside flange and the duct. Thread the matching split locking ring onto the fitting and tighten until snug. Using the appropriate size wrench on the locking ring and the flats on the fitting, tighten the locking ring until there is resistance to further tightening. Installation is complete. (Fig. 34)

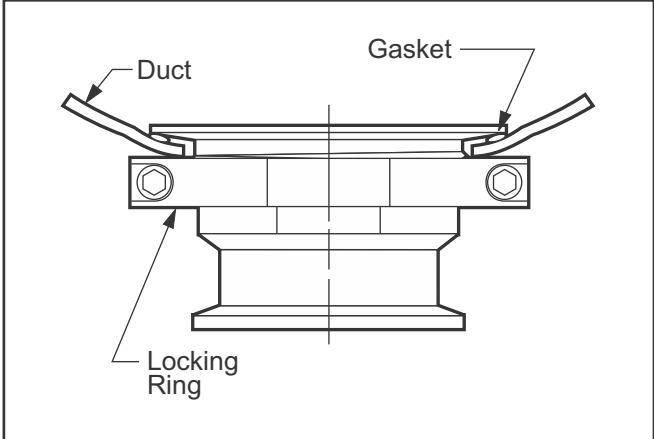

Fig. 34: Field Installed 2" FT Flange Configuration

**6. END OF PROCEDURE:**

METRIC EQUIVALENTS ARE SHOWN IN PARENTHESIS & ITALICS ( MILLIMETERS OR AS NOTED )

## Male Nipple Field Installation

### GENERAL:

The Field Installed Nipple has unique installation requirements. In order for this fitting to be installed, the duct section must be removed from the system or installed before the duct section is placed in the system. This fitting is available in three sizes with specific requirements for the host duct as indicated in the chart below.

PART NO.*	DESCRIPTION	MIN HOST DUCT SIZE
PRT01	1" (25.4) NPT NIPPLE	6" (152.4) DIA.
PRT15	1-1/2" (38.1) NPT NIPPLE	8" (203.2) DIA.
PRT02	2" (50.8) NPT NIPPLE	10" (254.0) DIA.

\*PART NO. INCLUDES: (1) NIPPLE, (1) JAM NUT & (1) GASKET

### MAXIMUM MATERIAL THICKNESS

16 GA (1.59) MAX FOR ALL 3 SIZES OF NIPPLE

### PROCEDURE: 1" (25.4) NPT NIPPLE

#### TOOLS REQUIRED:

Hydraulic Punch Kit (Fab-Tech PN TPS02)  
 Mechanical Punch Kit (Fab-Tech PN TPS01)  
 Electric or Pneumatic Drill  
 Drill Bit Set  
 Lint Free Cloth

**1. DRILL PILOT HOLE:** Drill a 3/8" (9.5) pilot hole in the duct at the desired location of the Test Port.

**2. 1-5/16" (33.3) PUNCH:** From the Hydraulic punch kit thread the 3/8" (9.5) stud onto the end of 3/4" (19.1) draw stud of the Greenlee hydraulic actuator. Slide the three spacers onto the 3/4" (19.1) actuator draw stud. Slide the 1-5/16" (33.3) die onto the 3/8" (9.5) stud with the open end of the die facing away from the actuator. Insert the 3/8" (9.5) stud through the pilot hole in the duct. From inside the duct thread the matching 1-5/16" (33.3) punch onto the 3/8" (9.5) stud with the cutting surfaces on the punch toward the duct. Continue threading the punch by hand until the die, duct and punch are snug. Operate the hydraulic actuator to draw the punch through the duct material. Remove the punch, die and 3/8" (9.5) stud. (Fig. 35)

**CAUTION:** Support the actuator and punch assembly during this operation. The punch assembly will drop out of the newly formed hole once it breaks through the duct material.

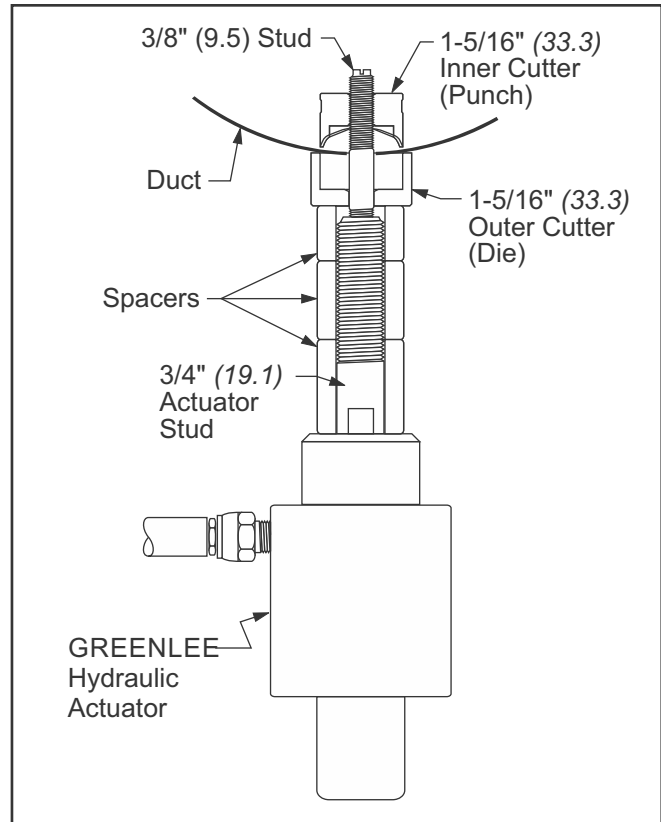

Fig. 35: 1-5/16" (33.3) Hydraulic Punch Configuration

**3. SWAGE HOLE:** Slide the 1-5/16" (33.3) outer swage tool onto the 3/4" (19.1) actuator stud. Insert the actuator stud and outer swage tool into the 1-5/16" (33.3) hole. From inside the duct slide the matching inner swage tool onto the actuator stud. Invert and thread the 1-5/16" (33.3) punch onto the actuator stud (cutting surfaces facing away from the inner swage tool) until the inner swage tool, the duct and the outer swage tool are snug. Operate the hydraulic actuator to compress the swage tools together to form the swage. Loosen and remove the swage tool. (Fig. 36)

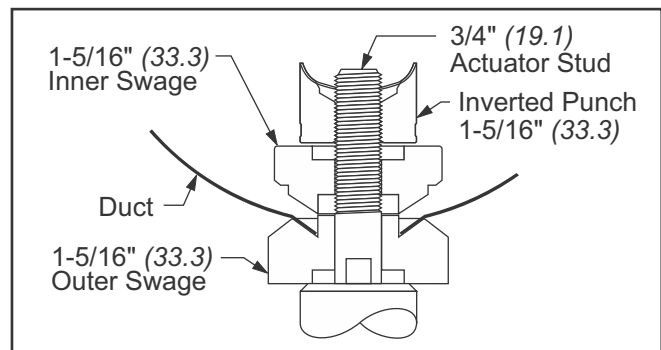

Fig. 36: 1-5/16" (33.3) Swage Configuration

#### 4. END OF PROCEDURE:

METRIC EQUIVALENTS ARE SHOWN IN PARENTHESIS & ITALICS (MILLIMETERS OR AS NOTED)

Male Nipple Field Installation

**PROCEDURE (cont'd):**

**4. INSTALL NIPPLE:** Remove backing and apply the die-cut gasket to the inside flange of the test port. Place the 1" (25.4) diameter test port in the swaged hole from inside the duct. Thread the matching jam nut onto the test port and tighten until snug. Using the appropriate size wrench on the jam nut and the flats on the test port, tighten the jam nut until there is resistance to further tightening. Installation is complete. (Fig. 37)

**5. END OF PROCEDURE:**

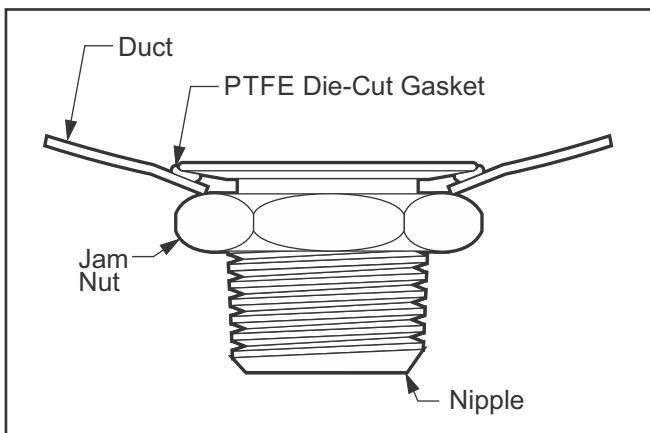

Fig. 37: Field Installed Nipple Configuration

**PROCEDURE: 1-1/2" (38.1) NIPPLE  
2" (50.8) NIPPLE**

**TOOLS REQUIRED:**

- Hydraulic Punch Kit (Fab-Tech PN TPS02)
- Electric or Pneumatic Drill
- Drill Bit Set
- Lint Free Cloth

**1. DRILL PILOT HOLE:** Drill a 3/8" (9.5) pilot hole in the duct at desired location of test port.

**2. 3/4" (19.1) PUNCH:** From the Hydraulic punch kit thread 3/8" (9.5) stud onto end of 3/4" (19.1) draw stud of the Greenlee hydraulic actuator. Slide the three spacers onto the 3/4" (19.1) actuator draw stud. Slide the 3/4" (19.1) die onto the 3/8" (9.5) stud with open end of the die facing away from the actuator. Insert the 3/8" (9.5) stud through the 3/8" (9.5) pilot hole. From inside the duct thread the matching 3/4" (19.1) punch

onto the 3/8" (9.5) stud with the cutting surfaces of the punch toward the duct. Continue threading the punch by hand until the die, duct and punch are snug. Operate the hydraulic actuator to draw the punch through the duct material. Remove the punch, die, 3/8" (9.5) stud and spacers. (Fig. 38)

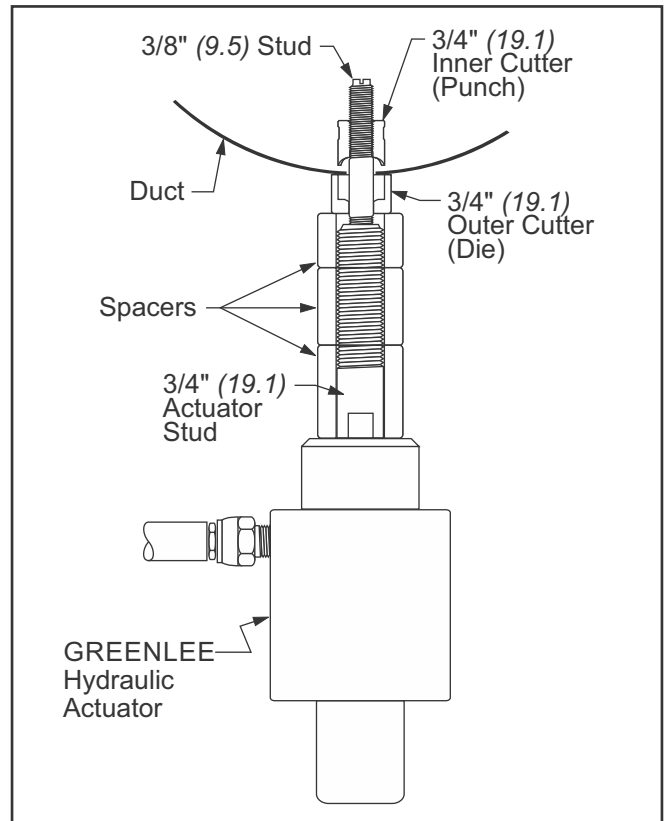

Fig. 38: 3/4" (19.1) Hydraulic Punch Configuration

**CAUTION:** Support the actuator and punch assembly during this operation. The punch assembly will drop out of the newly formed hole once it breaks through the duct material.

**3. 1-7/8 (47.6) PUNCH:** Slide the 1-7/8" (47.6) die (for 1-1/2" (38.1) test port) or the 60mm die (for 2" (50.8) test port) onto the 3/4" (19.1) actuator stud with the open end of the die facing away from the actuator. Insert the 3/4" (19.1) actuator stud into the 3/4" (19.1) hole. From inside the duct thread the matching 1-7/8" (47.6) or 60mm punch onto the 3/4" (19.1) actuator stud with the cutting surfaces of the punch toward the duct. Continue threading the punch by hand until the die, duct and punch are snug. Operate the hydraulic actuator to draw the punch through the duct material. Remove the punch and die. (Fig. 39)

METRIC EQUIVALENTS ARE SHOWN IN PARENTHESIS & ITALICS (MILLIMETERS OR AS NOTED)

## Male Nipple Field Installation

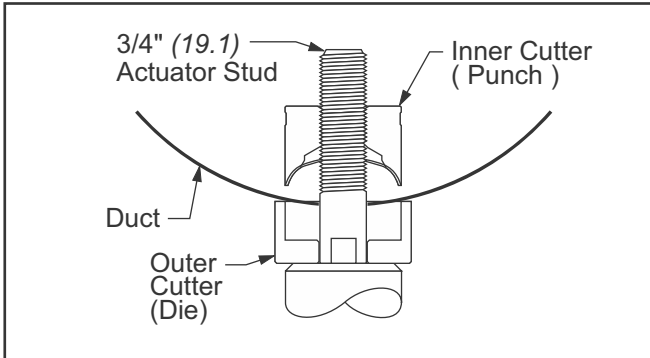
**PROCEDURE (cont'd):**

**Fig. 39:** 1-7/8" (47.6) Hydraulic Punch Configuration

**4. SWAGE HOLE:** Slide the 1-7/8" (47.6) outer swage tool (for 1-1/2" (38.1) test port) or the 60mm outer swage tool (for 2" (50.8) test port) onto the 3/4" (19.1) actuator stud. Insert the actuator stud and outer swage tool into the 1-7/8" (47.6) hole (for 1-1/2" (38.1) test port) or the 60mm hole (for 2" (50.8) test port). From inside the duct slide the matching inner swage tool onto the actuator stud. Invert and thread any one of the three punches onto the actuator stud (cutting surfaces facing away from the inner swage tool) until the inner swage tool, the duct and the outer swage tool are snug. Operate the hydraulic actuator to compress the swage tools together to form the swage. Loosen and remove the swage tool. (Fig. 40)

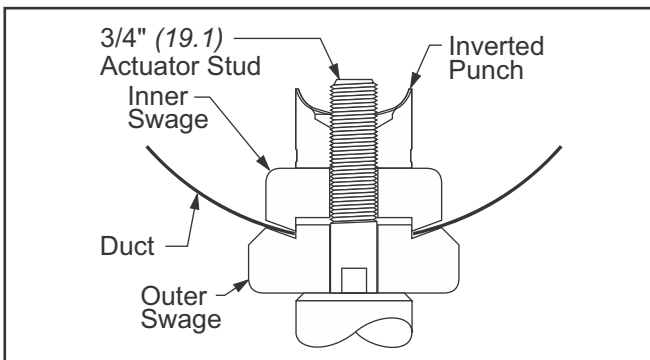

**Fig. 40:** 1-7/8" (47.6) Swage Configuration

**5. INSTALL NIPPLE:** Remove backing and apply die-cut PermaShield Gasket to the inside flange of the test port. Place the test port in the swaged hole from inside the duct. Thread the matching jam nut onto the test port and tighten until snug. Using the appropriate size wrench on the jam nut and the flats on the test port, tighten the jam nut until there is resistance to further tightening. Installation is complete. (Fig. 41)

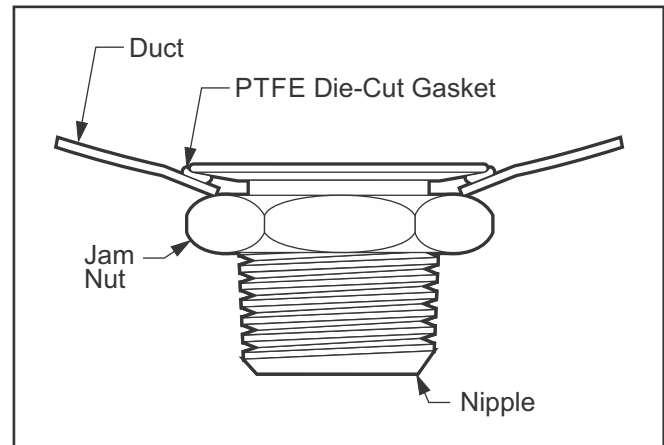

**Fig. 41:** Field Installed Nipple Configuration

**6. END OF PROCEDURE:**

**METRIC EQUIVALENTS ARE SHOWN IN PARENTHESIS & ITALICS (MILLIMETERS OR AS NOTED)**

Test Port (Lollipop) Field Installation: 3/8" (9.5), 3/4" (19.1) & 2" (50.8)

**PROCEDURE: 3/8" (9.5) TEST PORT**

**TOOLS REQUIRED:**

- Electric, Pneumatic, or Battery Powered Drill
- Drill Bit Set and Step Drill to 3/4" (19.1) Min Dia.
- Center Punch
- Half Round and Flat File (fine)
- Calibrated Torque Wrench

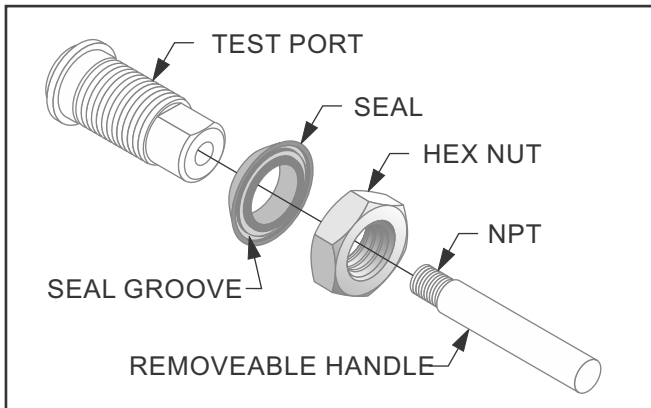

**Fig. 42:** 3/8" (9.5) Test Port Configuration

- 1. DRILL HOLE IN DUCT:** For this procedure, the duct does not need to be removed from the system and the port can be installed in duct as small as 2" (50.8) diameter. Mark the desired location for the test port and center punch. Drill a 1/8" (3.2) starter hole at the center punch location. Slowly enlarge the hole with a step drill to .750" (19.1) diameter hole in the duct.
- 2. DEBUR THE HOLE:** Carefully debur the hole removing all metal and coating debris.
- 3. APPLY ACCROLUBE TO SEAL:** Take the tube of Accrolube and use the tab ears to rip and twist the tip off. Hold the seal with the flared side toward you and apply a generous bead of Accrolube in the seal groove.

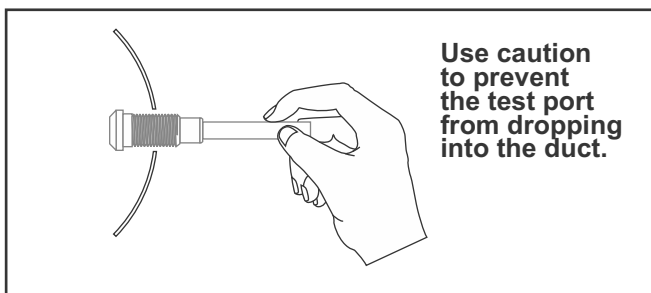
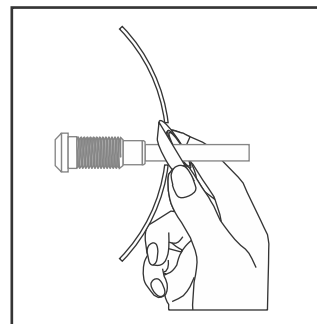

**Fig. 43:** Insert Test Port into duct

- 4. INSERT TEST PORT:** Work the test port into the hole until just the handle is showing outside the hole. (Fig. 43)
- 5. INSTALL SEAL:** Slide the seal, flared side away from the hole onto the handle. Using thumb and forefinger, squeeze the seal together and work it into the hole around the handle. (Fig. 44)
- 6. SEAT THE SEAL:** With the seal inside the duct and positioned on the test port shoulder, seat the seal lip in the hole by firmly pulling the handle so that the test port threads slide through the seal and protrude from the duct hole. Ensure that the seal lip is still seated in the hole. (Fig. 45)

- 7. INSTALL NUT:** Next, slide the nut onto the handle and thread the nut until it contacts the duct. Final tightening is with a calibrated torque wrench to 15 in-lbs (1.7 Nm). (Fig. 46)
- 8. REMOVE HANDLE:** The removable handle may be left in place as a temporary plug. Remove the handle to access a 1/16" (1.6) NPT tapped hole for installing a fitting of choice. The 3/8" (9.5) Test Port may be counter drilled to a maximum bore of 3/8" (9.5) ID for other installations. (Fig. 46)

**9. END OF PROCEDURE:**



**Fig. 44:** Install Seal

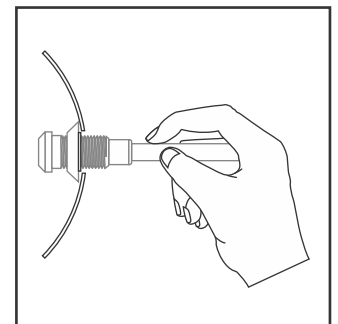

**Fig. 45:** Seat the Seal

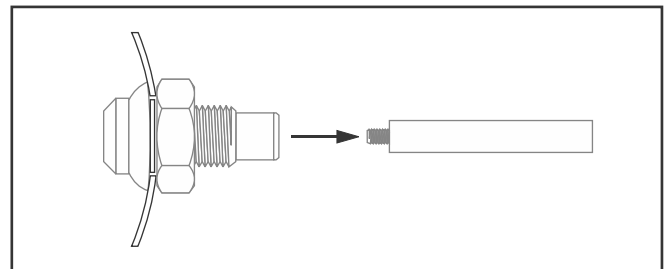

**Fig. 46:** Install Nut and Remove Handle

METRIC EQUIVALENTS ARE SHOWN IN PARENTHESIS & ITALICS (MILLIMETERS OR AS NOTED)



## Test Port (Lollipop) Field Installation: 3/8" (9.5), 3/4" (19.1) &amp; 2" (50.8)

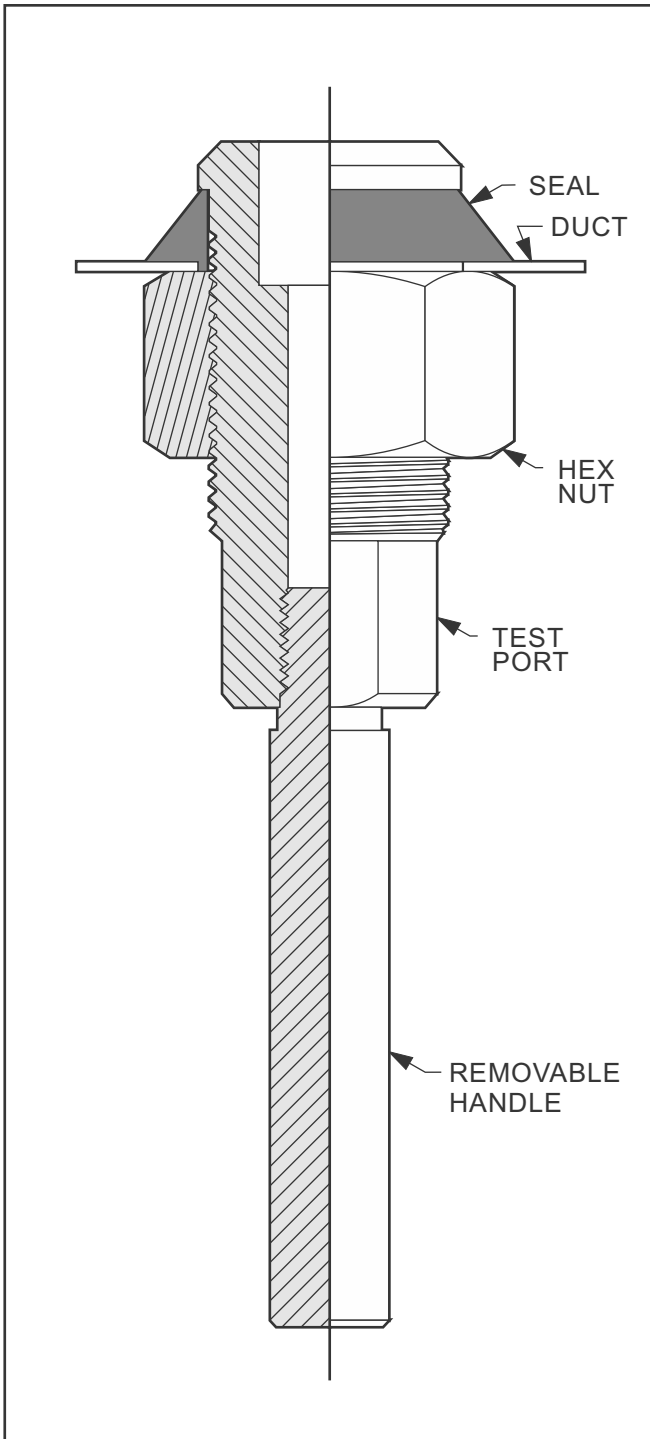

Fig. 47: 3/4" (19.1) Test Port Cut-away

### PROCEDURE: 3/4" TEST PORT

#### TOOLS REQUIRED:

Electric, Pneumatic, or Battery Powered Drill  
 Drill Bit Set and Step Drill to 1-3/8" (34.9) Min Dia.  
 Center Punch  
 Half Round and Flat File (fine)  
 Calibrated Torque Wrench

**1. DRILL HOLE IN DUCT:** For this procedure, the duct does not need to be removed from the system and the port can be installed in duct as small as 6" (152.4) diameter. Slowly enlarge the hole with a step drill to 1-3/8" (34.9) diameter hole in the duct.

**2. DEBUR THE HOLE:** Carefully debur the hole removing all metal and coating debris.

**3. APPLY ACCROLUBE TO SEAL:** Take the tube of Accrolube and use the tab ears to rip and twist the tip off. Hold the seal with the flared side toward you and apply a generous bead of Accrolube in the seal groove.

**4. INSERT TEST PORT:** Work the test port into the hole until just the handle is showing outside the hole. (Fig. 43)

**5. INSTALL SEAL:** Slide the seal, flared side away from the hole, onto the handle. Using thumb and forefinger, squeeze the seal together and work the seal into the hole around the handle. (Fig. 44)

**6. SEAT THE SEAL:** With the seal inside the duct and positioned on the test port shoulder, seat the seal lip in the hole by firmly pulling the handle so that the test port threads slide through the seal and protrude from the duct hole. Ensure that the seal lip is still seated in the hole. (Fig. 45)

**7. INSTALL NUT:** Next, slide the nut onto the handle and thread the nut until it contacts the duct. Final tightening is with a calibrated torque wrench to 250 in-lbs (28.2 Nm). (Fig. 46)

**8. REMOVE HANDLE :** The removable handle may be left in place as a temporary plug. Remove the handle to access a 1/4" (6.35) NPT tapped hole for installing a fitting of choice. The 3/4" (19.1) Test Port may also be drilled to a maximum bore of 3/4" (19.1) ID for other fitting installations. (Fig. 46)

**9. END OF PROCEDURE:**

**METRIC EQUIVALENTS ARE SHOWN IN PARENTHESIS & ITALICS (MILLIMETERS OR AS NOTED)**

## Test Port (Lollipop) Field Installation: 3/8" (9.5), 3/4" (19.1) &amp; 2" (50.8)

**PROCEDURE: 2" (50.8) TEST PORT****TOOLS REQUIRED:**

Electric, Pneumatic, or Battery Powered Drill  
 Hole Saw Arbor with Pilot Bit (be sure the arbor fits  
 hole saw sizes 1-1/4" (31.8) and 2-5/8" (66.7)  
 Bi-Metal Hole Saw 1-1/4" (31.8) Dia.  
 Bi-Metal Hole Saw 2-5/8" (66.7) Dia.  
 Center Punch  
 Half Round and Flat File (fine)  
 Calibrated Torque Wrench

**1. DRILL HOLE IN DUCT:** For this procedure, the duct does not need to be removed from the system and the port can be installed in duct as small as 12" (304.8) diameter. Mark the desired location for the test port and center punch. Drill a starter hole at the center punch location using the arbor pilot bit. Attach the 1-1/4" (31.8) hole saw onto the arbor. Using the starter hole as a guide, slowly drill a hole with the 1-1/4" (31.8) hole saw. Add the 2-5/8" (66.7) hole saw onto the arbor with the 1-1/4" (31.8) hole saw. Position the 1-1/4" (31.8) hole saw into the previously drilled hole using this as a guide, slowly drill a hole with the 2-5/8" (66.7) hole saw.

**2. DEBUR THE HOLE:** Carefully debur the hole removing all metal and coating debris.

**3. APPLY ACCROLUBE TO SEAL:** Take the tube of Accrolube and use the tab ears to rip and twist the tip off. Hold the seal with the flared side toward you and apply a generous bead of Accrolube in the seal groove.

**4. INSERT TEST PORT:** Work the test port into the hole until just the handle is showing outside the hole. (Fig. 43)

**5. INSTALL SEAL:** Slide the seal, flared side away from the hole, onto the handle. Using thumb and forefinger, squeeze the seal together and work the seal into the hole around the handle. (Fig. 44)

**6. SEAT THE SEAL:** With the seal inside the duct and positioned on the test port shoulder, seat the seal lip in the hole by firmly pulling the handle so that the test port threads slide through the seal and protrude from the duct hole. Ensure that the seal lip is still seated in the hole. (Fig. 45)

**7. INSTALL NUT:** Next, slide the nut onto the handle and thread the nut until it contacts the duct. Final tightening is with a calibrated torque wrench to 400 in-lbs (45.2 Nm). (Fig. 46)

**8. REMOVE HANDLE :** The removable handle may be left in place as a temporary plug. Remove the handle to access a 3/8" (9.5) NPT tapped hole for installing a fitting of choice. The 2" (50.8) Test Port may also be drilled to a maximum bore of 1-3/4" (44.5) ID for other fitting installations. (Fig. 46)

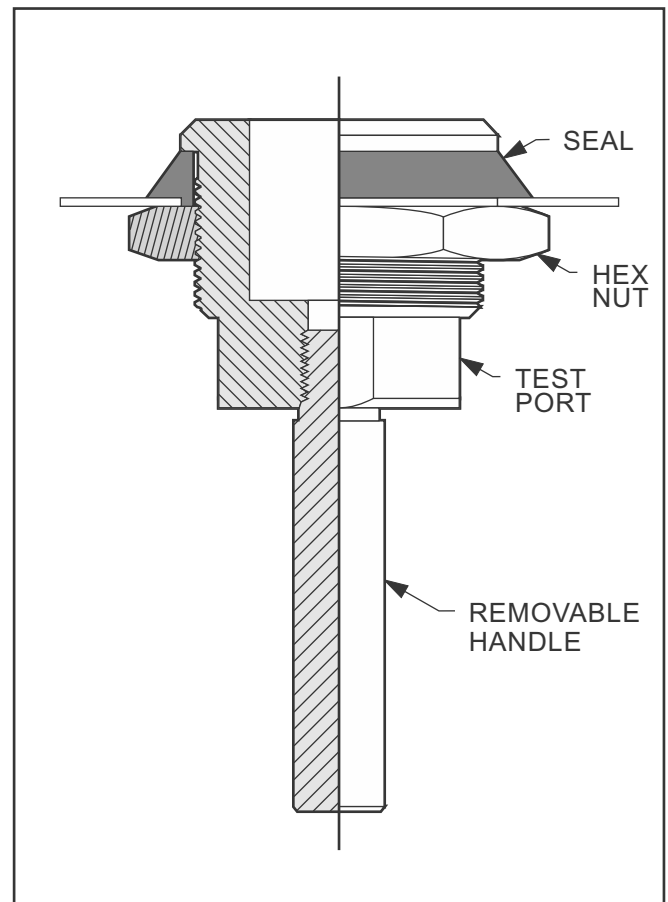
**9. END OF PROCEDURE:**

**Fig. 48:** 2" (50.8) Test Port Cut-away view

**METRIC EQUIVALENTS ARE SHOWN IN PARENTHESIS & ITALICS ( MILLIMETERS OR AS NOTED )**

## Fab-Tech Flange Assembly For Adapters

### GENERAL:

This procedure is intended to assist you in the proper assembly of our 2" (50.9) and 3" (76.2) Fab-Tech flange joint. All pieces are shipped in poly sheeting to help prevent contamination and to protect the outer coated surface of the flange. Remove the pieces from the poly sheeting and inspect the interior coated surface and the outer flange surfaces to insure the integrity of the system. Do not, under any circumstances, install a piece of pip or fitting that has visible damage. Do not penetrate the coating for any reason except when using approved modification systems. (Fig. 49)

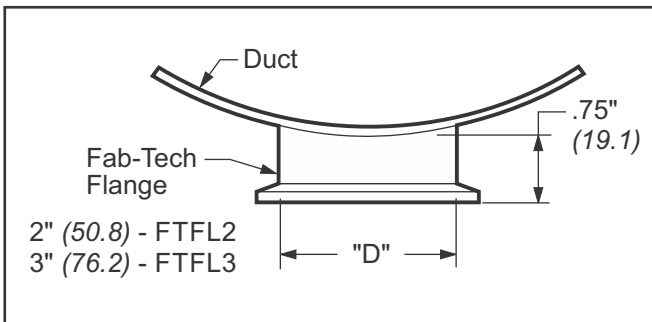

Fig. 49: Fab-Tech Flange Configuration

### PROCEDURE:

#### TOOLS REQUIRED:

Lint Free Cloth  
 Scissors and/or Utility Knife  
 Socket Set with Deep Sockets  
 Calibrated Torque Wrench

**1. POSITION CLAMP:** To begin, clean the outside flange surfaces to be joined with a soft damp cloth. Loosen and thread the clamp nut to the end of the bolt. Unclasp the buckle on the clamp. In this configuration the clamp has some flexibility. With moderate force, open the clamp until you are able to slip the clamp onto the flange welded to the duct.

**2. APPLY GASKET:** Always use a new gasket. Peel the backing from the die-cut PTFE gasket to expose the adhesive. Adhere the gasket approximately centered to one of the flange faces adhesive side down. Only one gasket required per joint. Firmly run your finger over the joint to guarantee complete adhesion.

**3. BRING FLANGES TOGETHER:** Carefully bring the piece to be installed into the clamp already positioned in Step 1. This will take some practice.

**4. Tighten Clamp:** When both flanges are trapped under the clamp band, reattach the buckle onto the clamp bolt and tighten the clamp nut until the joint sections stay together. Although this method of joining duct is self aligning, visually inspect the joint to ensure proper alignment of the flanges and proper seating of the flanges in the clamp. When satisfied that the alignment of the clamp and flanges are correct, tighten the clamp nut using a 7/16" (11.1) wrench until resistance to further tightening is felt.

**5. Torque Clamp Nut:** Final tightening must be done with a calibrated torque wrench. The recommended torque for 2" (50.8) & 3" (76.2) EZ clamps is 75 in lbs (6.25 ft lbs or 0.9 m kg). (Fig. 50)

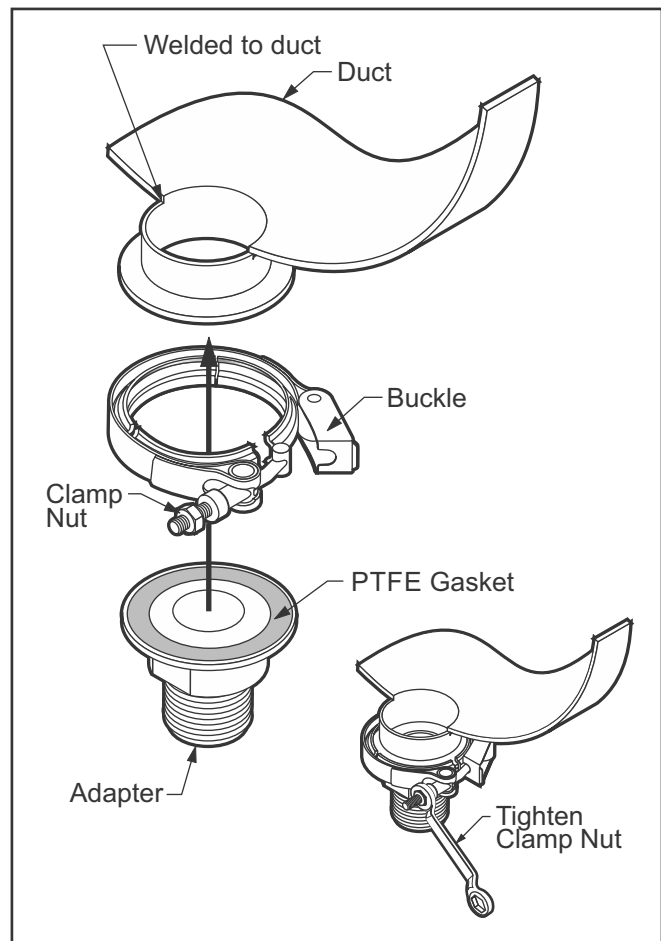

Fig. 50: Fab-Tech Flange Assembly

**6. END OF PROCEDURE:**

**METRIC EQUIVALENTS ARE SHOWN IN PARENTHESIS & ITALICS (MILLIMETERS OR AS NOTED)**

Damper Actuator Field Installation

**GENERAL:**

Fab-Tech's standard PermaShield dampers are manufactured in all sizes with a manual actuator. Pneumatic or electric actuators are also available as an option for all sizes of dampers. However, customer supplied actuators are also an option. This procedure covers the steps required to modify each of the type of dampers in the field to accept a customer supplied actuator. Since this procedure cover the full range of dampers from 4" (101.6) to 120" (3048.0) diameter, the steps described below are general in nature.

**PROCEDURE:**

**TOOLS REQUIRED:**

- Custom Actuator Kit
- Blank Actuator Mounting Plate
- Blank Actuator Shaft
- Assorted Box Wrenches
- Assorted Allen Wrenches

**1. REMOVE MANUAL ACTUATOR:** For all sizes of dampers, reference the appropriate illustration to remove the manual actuator, mounting plate and actuator shaft. (Fig. 56, 57,58, 59) Set these items aside.

**2. MACHINE BLANK ACTUATOR SHAFT:** Take the blank actuator shaft and have it machined to mate with the customer supplied actuator.

**3. MODIFY BLANK ACTUATOR MOUNTING PLATE:** Take the blank actuator mounting plate and have it drilled with the correct size and number of holes to mount the customer supplied actuator.

**4. ACTUATOR ASSEMBLY:** Attach the customer supplied actuator onto the modified actuator mounting plate. Install the new actuator, actuator mounting plate and shaft onto the damper. Reuse the hardware removed in Step 1 to install the actuator mounting plate and reuse the setscrew to attach the modified actuator shaft to the damper blade shaft.

**5. TEST ACTUATOR:** Test new actuator to insure that the damper operates properly.

**6. END OF PROCEDURE:**

**TECHNICAL ASSISTANCE:**

For technical assistance, contact the Fab-Tech Engineering Department at (802) 655-8800.

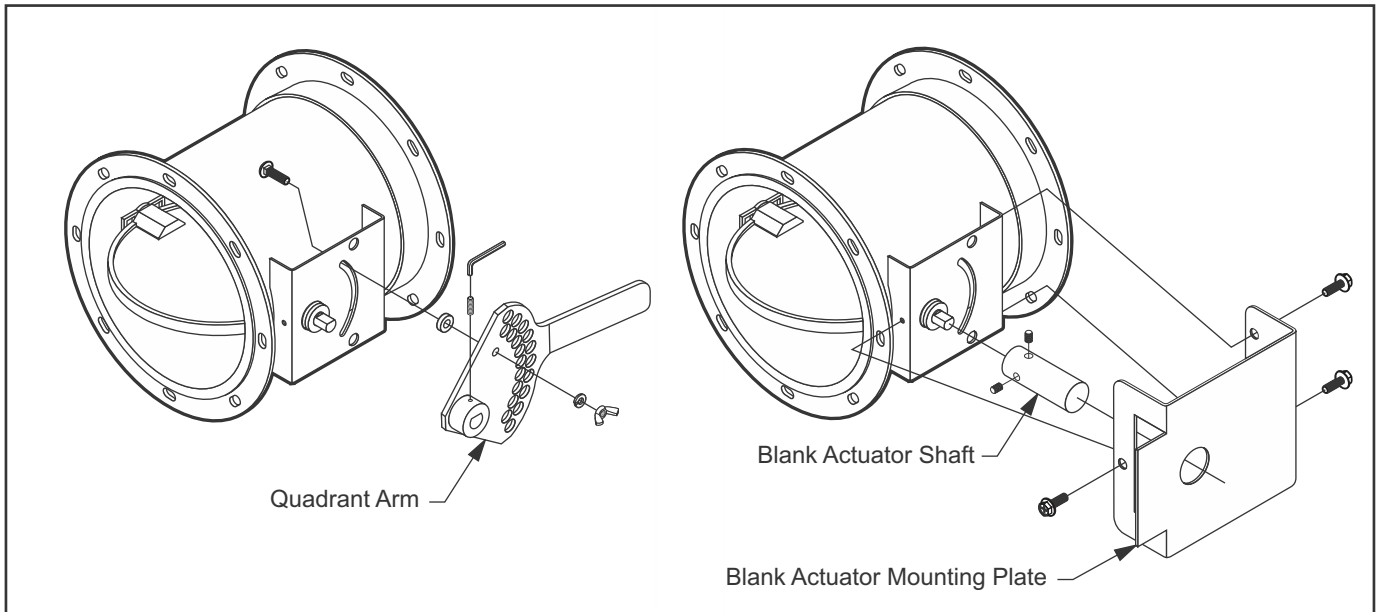
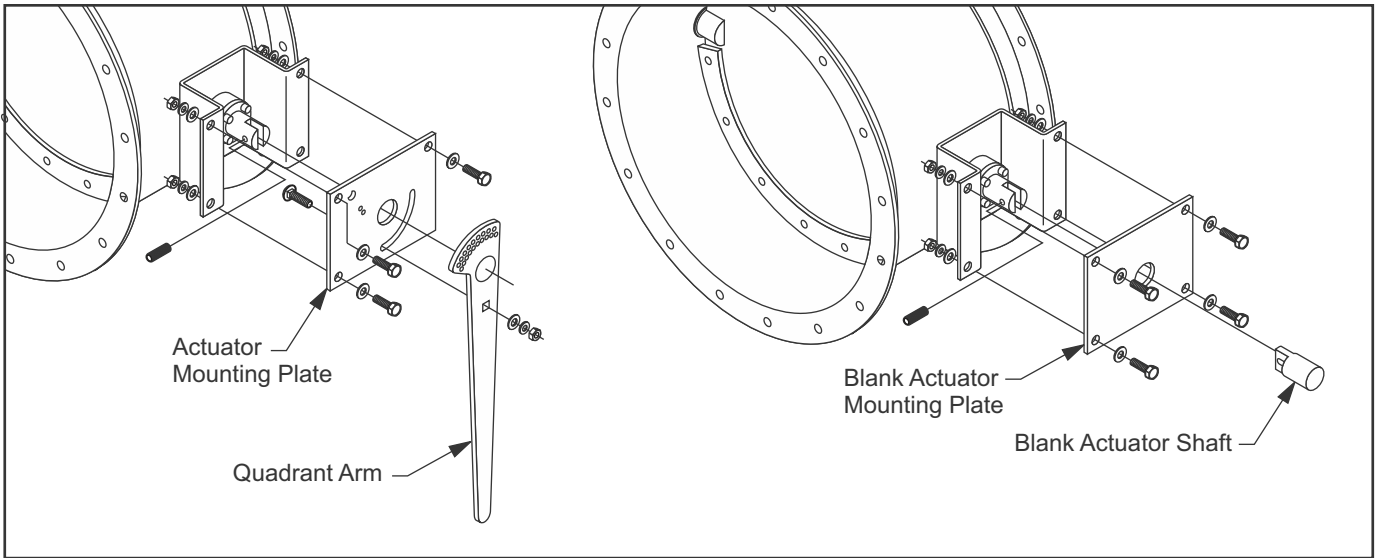

Fig. 51: 4" (101.6) - 14" (355.6) Industrial Damper Actuator Removal for Customer Supplied Actuator.

METRIC EQUIVALENTS ARE SHOWN IN PARENTHESIS & ITALICS ( MILLIMETERS OR AS NOTED )

Damper Actuator Field Installation



**Fig. 52:** 16" (406.4) - 34" (863.6) Heavy Duty Industrial Damper Actuator Removal for Customer Supplied Actuator.

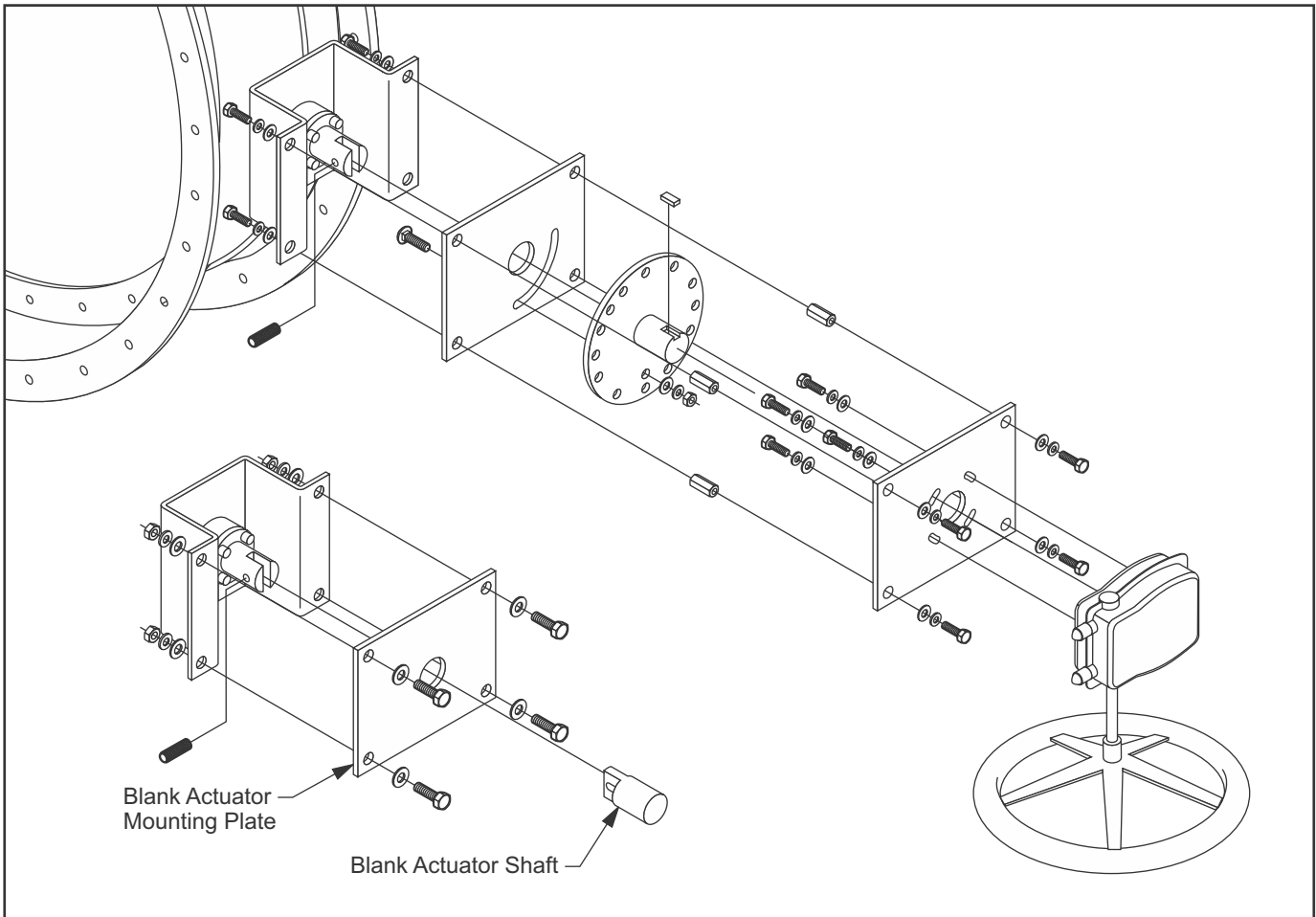

**Fig. 53:** 36" (914.4) - 48" (1219.2) Heavy Duty Industrial Damper Actuator Removal for Customer Supplied Actuator.

**METRIC EQUIVALENTS ARE SHOWN IN PARENTHESIS & ITALICS (MILLIMETERS OR AS NOTED)**

Damper Actuator Field Installation

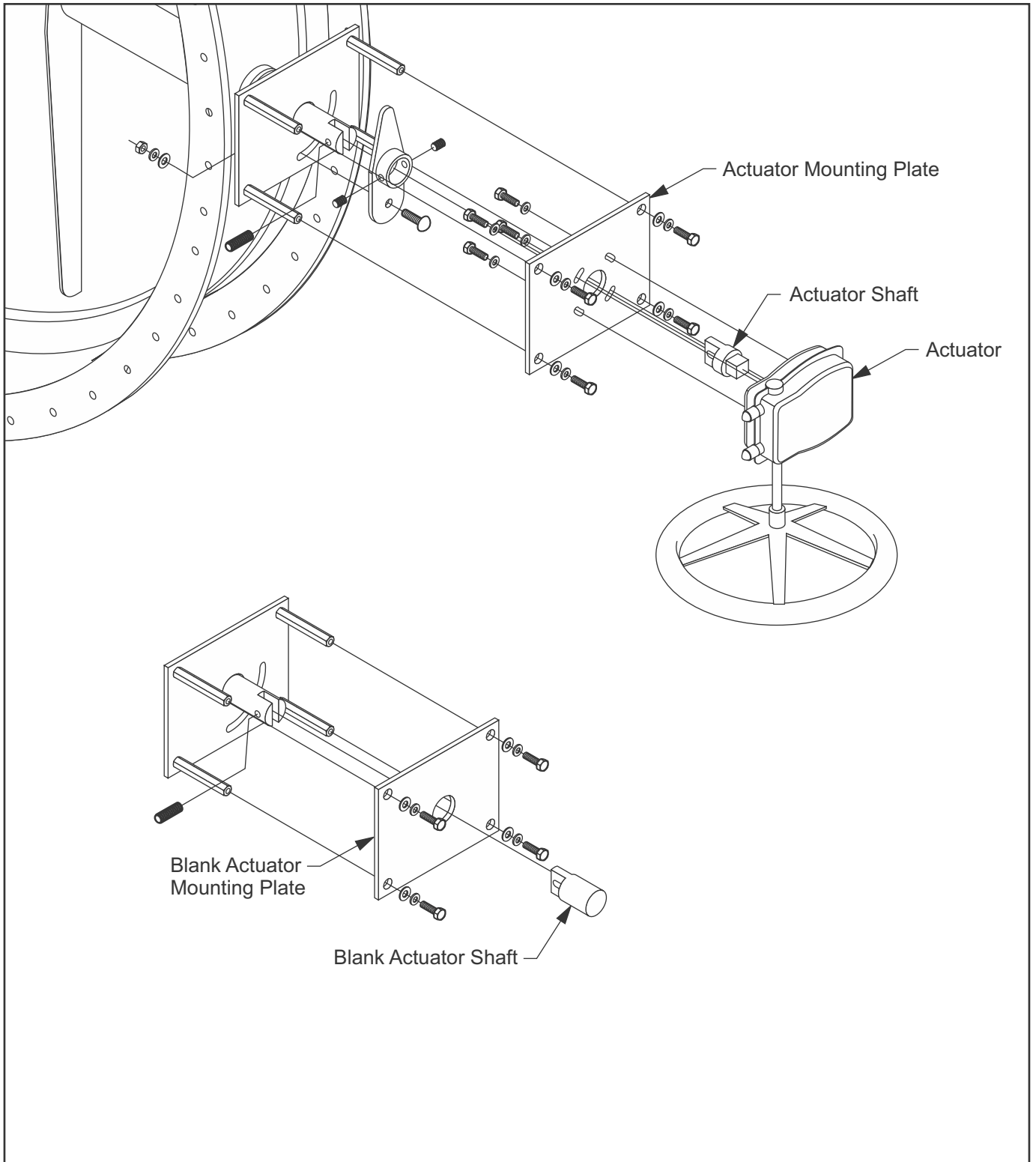

**Fig. 54:** 50" (1270.0) and Larger Reinforced Heavy Duty Industrial Damper Actuator Removal for Customer Supplied Actuator.

**METRIC EQUIVALENTS ARE SHOWN IN PARENTHESIS & ITALICS ( MILLIMETERS OR AS NOTED )**

## PermaShield Coating Repair with PermaPatch

### GENERAL:

Repair of small pinholes and abrasions on Fab-Tech's PermaShield coated duct may be accomplished. This repair protocol is appropriate for repairs no larger than a dime (1/2" (12.7) diameter). The patch material comes as clear 1" (25.4) diameter film dots and will provide an overlap of 1/4" (6.35) around the entire perimeter of the damage/defect.

Contact Fab-Tech Engineering for specific restoration protocol for larger repairs.

### PERSONAL PROTECTION:

Work only in a well-lit and ventilated area as fumes will be generated. If working in a confined area, follow your corporate confined space precautions, remembering that a heat source will be used. An NIOSH-approved respirator, not a dust mask, should be used if ventilation, is marginal. Safety glasses are required. Carefully read the Safety Data Sheets (SDS) for the PermaPatch repair film.

## PROCEDURE

### MATERIALS NEEDED:

Fab-Tech PermaPatch Repair Kit, Item #PP-KIT  
(Contact Fab-Tech Sales at 802-655-8800)  
Electric Heat Gun: Milwaukee Veritemp Model #8977  
with Concentrator Accessory #49-80-0297 or  
Bosch Heat Gun Model #1943LED with  
Concentrator #HG020  
Denatured Alcohol (or Alcohol Prep Pads)  
Tweezers  
#220 Grit Aluminum Oxide (A/O) Sandpaper  
Safety Glasses  
NIOSH Approved Respirator with Hepa/Charcoal  
Combination Cartridge Filter

### TRAINING VIDEO:

Fab-Tech's PermaShield Training Video has a short section on coating repair. This video is available online at [www.fabtechinc.com/training\\_videos.php](http://www.fabtechinc.com/training_videos.php).

### REPAIR PROCEDURE:

As this is a heat application process, make certain that all tools and materials are "ready-to-go". The patch area must not be allowed to cool from start to finish. Practice this patch technique on a Fab-Tech coated coupon for practice.

#### 1. CLEAN THE IMMEDIATE AREA:

Normally the patch area does not need to be sanded. However, if the area requiring repair is caused by an abrasion then it may be necessary to locally lightly sand with 220 grit aluminum oxide sandpaper, removing all embedded contamination. All foreign material must be removed from the patch area and sharp "edges" or bumps should be sanded smooth. In all cases, wipe the entire area with an alcohol moistened lint free towel. Repeat using another clean lint free towel. The patch should also be cleaned with alcohol.

#### 2. PREHEAT TO GLAZE:

Using the Heat Gun set to 820-850°F (440-455°C) uniformly preheat in and around the area to be patched. Stop preheating at the time when the area becomes glazed over. Caution: Avoid overheating which can burn the coating.

#### 3. TACKING THE PATCH:

While maintaining the heat and glaze, using tweezers, center the patch carefully over the area. Using ePTFE material, press the patch into softened coating. Patch should have a minimum 1/4" (6.35) clearance around the coating.

#### 4. FINAL REHEAT TO FLOW:

Using the heat gun in an even circular motion, heat the patch and area until no gaps or voids are present. The properly repaired area should be free of bubbles, folds and raised edges.

Caution: Avoid overheating which can burn the coating.

#### 5. TESTING THE PATCH:

After the patch has cooled, follow the approved "spark" testing protocol to assure that the area is "holiday" free. Refer to Spark Testing Protocol included in this assembly guide.

### TECHNICAL ASSISTANCE:

If you need technical assistance, call the Fab-Tech Inc. Engineering Department at (802) 655-8800.

**METRIC EQUIVALENTS ARE SHOWN IN PARENTHESIS & ITALICS (MILLIMETERS OR AS NOTED)**

**GENERAL:**

PermaShield products are 100% QC tested at the factory for coating defects. However, there are times when field spark testing is recommended. Inspect any duct that may have been damaged during transport or installation, or has been field shortened or modified.

**SPARK TESTER:** The spark tester is a battery operated high voltage, low amperage, voltage source. It is recommended that a D.E. Stearns Holiday tester be used for this procedure. On the face of the unit is a large black on/off switch. Below and to the left and right of this switch are the electrode and ground connections. The ground cable has a copper colored cable molded into the end. The electrode cable has connectors on each end. Connect the ground and electrode cables to the appropriate cable connection. The connectors are quarter turn style. Insert and rotate the connector until the slotted end engages. Moderate insertion force is normal. Turn the connector clockwise to lock. The insulated wand and brush fixtures attach to the other end of the electrode cable using the same connector style. (Fig. 54)

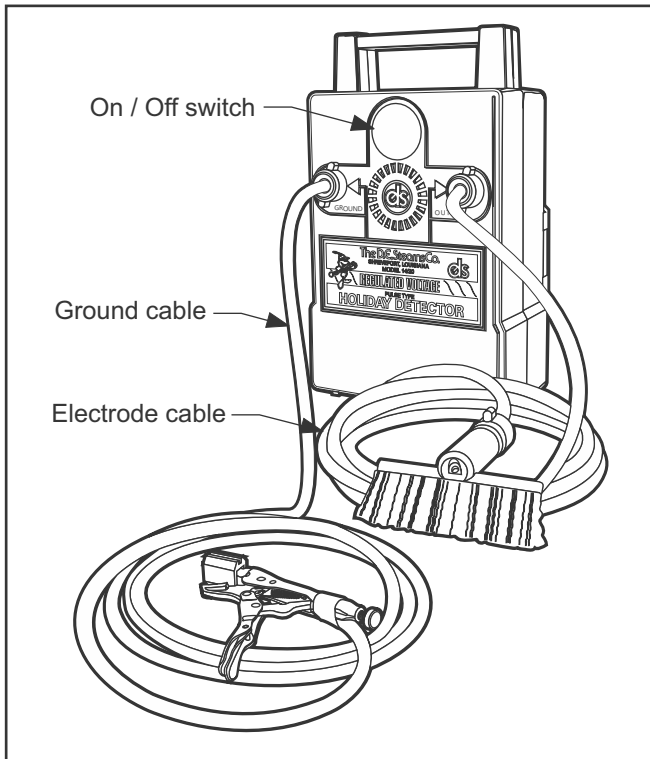

Fig. 55: D.E. Stearns Spark Tester

**PROCEDURE:**

**1. SET THE TESTER:** On the back of the unit are two black, slotted screws caps. (Fig. 55) Remove these caps to expose the adjusting screws underneath. Set the spark tester to achieve 2500 volts. Set the High/Low selector to Low and set eh numeric selector to eight. Test the unit by switching it on and grounding the electrode brush against the ground strap. The resulting audible tone should become noticeably louder.

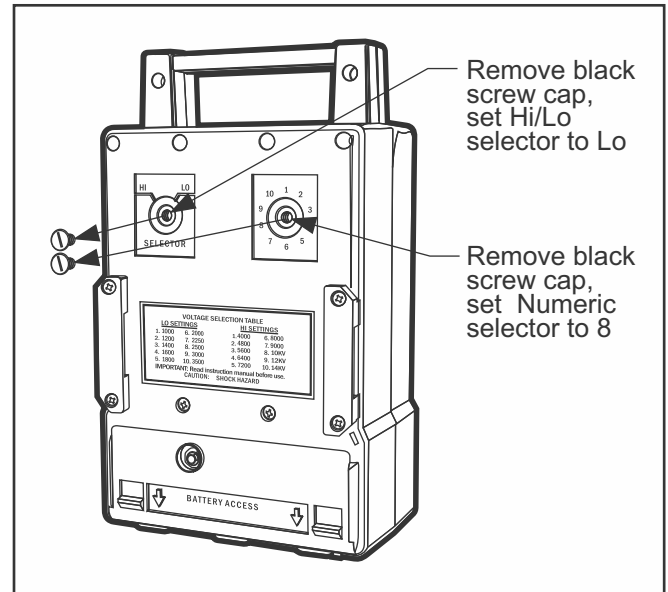

Fig. 56: Rear View of Spark Tester

**CAUTION:** This device will bite. Although the amperage of the device is not dangerous, it will create an uncomfortable shock. Make sure that you do not create a ground path with your body.

**2. GROUND STRAP:** Make sure the ground strap is in contact with ONLY the base metal of the duct to be tested (do not use loose rings or painted surfaces as ground). Then check that the tester works by touching the duct metal with the brush. A good spark and an increase in tone tells you that it is connected properly.

**3. INSPECT DUCT:** Inspect the duct coating. Make sure the area to be tested is clean and dry. Be careful to draw the brush toward you; do not push the tips of the brush into the coating. The long brush can be used to inspect large areas of the inside of the duct in a sweeping motion.

METRIC EQUIVALENTS ARE SHOWN IN PARENTHESIS & ITALICS ( MILLIMETERS OR AS NOTED )



## Spark Testing Protocol

**PROCEDURE (cont'd):**

**3. INSPECT DUCT (cont'd):** The smaller brass brush can be used to inspect the coating that may have been damaged, modified, or to inspect very near the flange edge. Watch very closely for sparks near the edge to make sure it is not a result of bringing the brush too close to the sheet metal.

**4. PASS/FAIL:** If there is no detection of voids in the coating, the piece or modification "passes". If a void in the coating is detected the piece "fails" (a detectable visual spark/crackling sound and an audible sound from the tester will be heard). Approach a subject spot to isolate the source of the spark. Use tape or a marker to identify the location of the defect. It is imperative NOT to use this piece until corrected.

**5. FINAL DISPOSITION:** Visually inspect the "failed" area; a repair may be possible using a Fab-Tech Repair Kit and follow the appropriate repair procedure. If the piece is "rejected", it **MUST NOT** be placed in service. Contact Fab-Tech for repair or replacement.

**HOLIDAY DETECTOR:** The Model 14/20 Holiday Detector from D.E. Sterns shown in this procedure is no longer in production. The new Model 14/20 unit is shown below for your reference.



**Fig. 57:** D.E. Sterns new Model 14/20 Holiday Detector.

**METRIC EQUIVALENTS ARE SHOWN IN PARENTHESIS & ITALICS (MILLIMETERS OR AS NOTED)**

The following is a list of tools and materials used in all the instruction sections of this guide.

### Standard

- Electric double cut shears (Milwaukee 6850 or equiv )
- Flexible metal ruler and/or tape measure
- Marking pen and/or scribe
- Calculator and writing pad
- Protective gloves
- Electric or pneumatic drill
- Center punch
- Drill bit set and step drill to 1/2" (*13mm*) min diameter
- Hacksaw with blades (32 or 40 teeth per inc.)
- Socket set with deep sockets for EZ clamp bolts
- Torque wrench 0-50 lb\*ft (*0-70NM*)
- Half round and flat file (fine)
- Hard rubber or leather mallet (must be clean and new)
- Scissors and/or utility knife
- Large adjustable wrenches (tighten adapter locknuts)
- Allen wrenches for assembling split colars
- Soft cloths for cleaning
- Alcohol for cleaning

### Special

- Hydraulic punch kit (Fab-Tech PN TPS02)
- Mechanical punch kit (Fab-Tech PN TPS01)
- EZ pliers (Fab-Tech PN ezpliers)
- Saw guides for cutting 2" & 3" (*50.8mm & 76.2mm*) EZ duct  
(Tri-Clover 2" model #07-1014-2A and 3" model #07-1014-3A)
- Ridgid model S3 heavy duty pipe cutter  
(Fab-Tech PN D0700 custom roller)
- Hand flanger - Pexto model 622 or equivalent  
(Custom rolls for hand flanger)

**METRIC EQUIVALENTS ARE SHOWN IN PARENTHESIS & ITALICS ( MILLIMETERS OR AS NOTED )**